

Amphenol

C 091 A/B/D



Circular Connectors

Amphenol-Tuchel Electronics GmbH

General information

These connectors are designed and produced in conformity with the low-voltage directive (72/23/EWG) respectively Gerätesicherheitsgesetz (German law).

We reserve the right to change the design due to improvement in quality, development or production requirements.

Content

Page

Remarks / Safety classification

4

IP Codes

5

C 091 A



7

Circular connectors with metal screw coupling and plastic back shell. Wire strain relief is metal half shell construction for shielding. Contact positions in 2 to 8, 12 and 14.

C 091 B



21

Circular connectors with plastic bayonet coupling and back shell. Wire strain relief is metal half shell construction for shielding. Contact positions in 3 to 8, 12 and 14. Wire strain relief available in plastic, see page 32.

C 091 D



37

Circular connectors with metal screw coupling and back shell. Wire strain relief is metal shell construction for shielding. Contact positions in 3 to 8, 12 and 14.

Crimp contacts

46

Accessories

47

Summary of Part Numbers

48



1. General Remarks

These connectors are designed and produced in conformity with the low voltage directive (72/23/EWG) respectively Gerätesicherheitsgesetz (German law). We reserve the right to change the design due to improvement in quality, development or production requirements. These connectors and/or plug and socket devices are designed and produced according to DIN VDE 57627. All technical data refer to mated connectors under live conditions. The safety of the connector system depends on the correct selection of products, proper assembly of the connector device, and a precise fit of the connectors.

2. Application Remarks

Connectors and/or plug and socket devices must be used according to specified technical ratings. The technical data represent the initial value of mated parts under predetermined conditions and length of time. These values could change with different test parameters or product requirements. The C 091 Series connectors are used in a wide variety of industries and equipment. Some of these include industrial machines and controls, data processing, instrumentation and test equipment, medical devices, telecommunication's network and equipment, plus outdoor and marine applications. All rated data for the connectors listed in this catalog are based on over-voltage category and pollution degree for electronic applications. Connectors were completely mated according to their respective safety locking mechanism. Selection and testing of connectors and/or plug and socket devices to meet specific product or industrial requirements such as rated voltage and the related clearances and creepage distances are the responsibility of the user.

3. Assembling Remarks

Certain appliances and equipment include protective measures that relate to the coupling devices of the male and female receptacle housings. (see also DIN VDE 0100 part 410; IEC 60364-4-41). Care must be taken to insure the parts are correctly mated and screws are tightened with the proper torque.

4. Termination Remarks

Cable connectors are effectively secured when using the internal cable clamp. When the connector contains a simple gland bushing for retention the cable should have a strain relief close behind the connector. All cable properties or specifications must be compatible with the connector design and materials. Designated wire conductors must be terminated to the correct poles in the connector. Crimp contacts must be fully inserted into the plastic housing and retention assured with a slight tug on the wire. Wire should be stripped correctly according to printed specifications to ensure no electrical contact can be made between the conductors. There should be no nicked or cut strains during the stripping action.

5. Safety Classification acc. to DIN VDE 0627

Style	Safety classification ¹⁾			Connectors		Protective earth contact		Protection against electric shock		Cable clamp	
	A	B	C	free	fixed	with	without	mated	unmated	with	without
Male cable connector	X	X	X	X			X	X		X	X
Female cable connector	X	X	X	X			X	X	X	X	X
Male receptacle	X	X			X		X	X			X
Female receptacle	X	X			X		X	X	X		X

¹⁾ A Connections to and from a device equipment B Connections within a device equipment C Free cable connections

Degree of protection

Electrical devices to which connectors belong have to be protected for safety reasons from outside influences like dust, foreign objects, direct contact, moisture and water. This protection is provided on industrial connectors by their housings with their latching devices and sealed cable entries. The degree of protection can be selected depending on the type of intended use. The standard IEC 60529 and/or DIN EN 60529 has specified the degree of protection and divided into several classes.

The degree of protection is indicated in the following way:

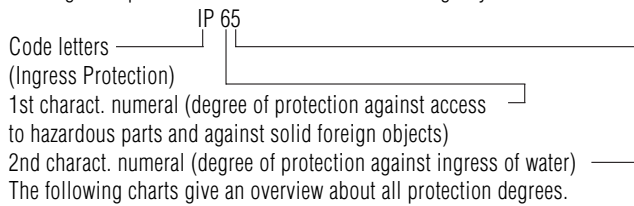

1st charact. numeral	Brief description	Definition
0	Non-protected	—
1	Protected against access to hazardous parts with the back of a hand. Protected against solid foreign objects of $\geq 50\text{mm } \varnothing$.	The probe, sphere of 50mm \varnothing , shall not fully penetrate and shall have adequate clearance from hazardous parts.
2	Protected against access to hazardous parts with a finger. Protected against solid foreign objects of $\geq 12.5\text{mm } \varnothing$.	The jointed test finger of 12mm \varnothing , 80mm length, shall have adequate clearance from hazardous parts. The probe, sphere of 12.5mm \varnothing , shall not fully penetrate.
3	Protected against access to hazardous parts with a tool. Protected against solid foreign objects of $\geq 2.5\text{mm } \varnothing$.	The probe of 2.5mm \varnothing shall not penetrate at all.
4	Protected against access to hazardous parts with a wire. Protected against solid foreign objects of $\geq 1\text{mm } \varnothing$.	The probe of 1mm \varnothing shall not penetrate at all.
5	Protected against access to hazardous parts with a wire. Dust-protected.	The probe of 1mm \varnothing shall not penetrate. Intrusion of dust is not totally prevented, but dust shall not penetrate in a quantity to interfere with satisfactory operation of the device or to impair safety.
6	Protected against access to hazardous parts with a wire. Dust-tight.	The probe of 1mm \varnothing shall not penetrate. No intrusion of dust.

2nd charact. numeral	Brief description	Definition
0	Non-protected	—
1	Protected against vertically falling water drops	Vertically falling drops shall have no harmful effects.
2	Protected against vertically falling water drops when enclosure tilted up to 15°	Vertically falling drops shall have no harmful effects when the enclosure is tilted at any angle up to 15° on either side of the vertical.
3	Protected against spraying water	Water sprayed at an angle up to 60° on either side of the vertical shall have no harmful effects.
4	Protected against splashing water	Water splashed against the enclosure from any direction shall have no harmful effects.
5	Protected against water jets	Water projected in jets against the enclosure from any direction shall have no harmful effects.
6	Protected against powerful water jets	Water projected in powerful jets against the enclosure from any direction shall have no harmful effects.
7	Protected against the effects of temporary immersion in water	Intrusion of water in quantities causing harmful effects shall not be possible when the enclosure is temporarily immersed in water for 30 min. in 1m depth.
8	Protected against the effects of continuous immersion in water	Intrusion of water in quantities causing harmful effects shall not be possible when the enclosure is continuously immersed in water under conditions which shall be agreed between manufacturer and user but which are more severe than for numeral 7.
9 K ¹⁾	Protected against water during high pressure/steam jet cleaning	Water projected in powerful jets with high pressure against the enclosure from any direction shall have no harmful effects.

1) Remark: Numeral acc. to DIN 40050 part 9, vehicles IP code

C 091 A



Main Features

- Metal threaded coupling acc. to IEC 130-9.
- Number of contacts are 2 to 8, 12 and 14.
- Internal metal strain relief with half shell construction and snap-in latching.
- Complete EMI shielding in fully mated and locked position.
- Male and female cable connectors: solder in 2 to 8, 12,14 positions; crimp in 3 to 8 positions; cable outlet PG 7 for diameter of 6 mm; cable outlet PG 9 for diameters of 6.5 mm and 8 mm; cable entry straight or right-angled; metal coupling nickel plated or plastic coated.
- Male and female receptacles for panel mount: front or rear mounting; solder in 2 to 8, 12, 14 positions; crimp in 3 to 8 positions; PCB mounting, straight and right-angled, using dip solder termination with multiple tail lengths.
- Coloured back-shells for coding, see page 47
- The connectors are registered under File # E 63 093 UL.



UNDERWRITERS LABORATORIES INC.

C 091 A

Characteristics

General Characteristics	Standard	Characteristics									
Number of contacts		2 + 3	4	5	5 Stereo	6	7	7	8	12	14
View on termination side of contact insert											
Contact arrangement acc. to DIN		41 524	–	–	41 524	41 322	–	45 329	45 326	–	–
Contact arrangement acc. to IEC		130-9	–	–	130-9	130-9	–	130-9	130-9	–	–
Electrical Characteristics											
Rated voltage	IEC 60664-1	300 V ≈			100 V ≈	300 V ≈			150 V ≈		
Rated impulse withstand voltage	IEC 60664-1	1500 V			1200 V	1500 V			1200 V		
Pollution degree	IEC 60664-1	1									
Installation category	IEC 60664-1	I									
Insulation group	IEC 60664-1	3									
Test voltage	IEC 60664-1	980 V ~			670 V ~	980 V ~			670 V ~		
Current rating	IEC 60512-3 Test 5 b	5 A / + 40 °C / + 104 °F								3 A / + 40 °C / + 104 °F	
Insulation resistance	IEC 60512-2 Test 3 a	> 10 ¹² Ω									
Contact resistance	IEC 60512-2 Test 2 a	< 5 m Ω									
Climatical Characteristics											
Climatic category	IEC 60068-1	40 / 85 / 56									
Temperature range	IEC 60068-1	- 40 °C ... + 85 °C / - 40 °F ... + 185 °F									
Mechanical Characteristics											
IP-degree	IEC 60529	IP 40									
Insertion and withdrawal forces	IEC 60512-7 Test 13 b	25 N 90.oz	30 N 110.oz	35 N 125.oz	50 N 180.oz	55 N 200.oz	60 N 220.oz	60 N 220.oz	50 N 180.oz		
Mechanical operation	IEC 60512-5 Test 9 a	Silver ≥ 500 mating cycles Gold ≥ 1000 mating cycles									
Materials											
Housing material		coupling ring brass, strain relief, die cast, nickel plated									
Dielectric material		thermoplastic									
Contact plating		silver plated / gold plated *									
Further Characteristics											
Termination technique		solder, crimp								solder	
Wire gauge		solder ≤ 0,5 mm ² (20-26 AWG), crimp 0,14 – 1,0 mm ² (26-18 AWG)								≤ 0,25 mm/24 AWG	
Flammability		UL 94 V0									
Locking system	IEC 103-9	metal screw coupling									

Characteristics

Do not connect or disconnect under load. Metal housing parts shall be securely incorporated to protected ground.

* Remark for gold plated contacts

To avoid brittle intermetallic connections gold-plated soldering terminals must be pre-tinned before soldering.

C 091 A

Male cable connector,
screw locking,
straight



Cable outlet 6 mm



Cable outlet 8 mm



Cable outlet 6.5 mm



Cable outlet 6 mm

Description	Drawing	No. of cont.	Part Number solder termination		Part Number Crimp termination ¹⁾		
			Contact plating silver	Contact plating gold ²⁾			
Male cable connector, max. cable outlet 6 mm, termination: solder or crimp, contact plating: silver or gold.		2	T 3200 001	T 3200 018	–		
		3 DIN	T 3260 001	T 3260 018	T 3260 551		
		4 IEC	T 3300 001	T 3300 018	T 3300 551		
		5	T 3360 001	T 3360 018	T 3360 551		
		5 S DIN	T 3360 010	T 3356 018 ⁴⁾	T 3356 551		
		6 DIN	T 3400 001	T 3400 018	T 3400 551		
		7	T 3475 001	T 3475 018	T 3475 551		
		7 DIN	T 3484 001	T 3484 018 ⁴⁾	T 3484 551		
		8 DIN	T 3504 001	T 3504 018	T 3504 551		
		12	T 3635 001	T 3635 000	–		
		14	T 3650 001	T 3650 000	–		
		Male cable connector, max. cable outlet 8 mm, termination: solder or crimp, contact plating: silver or gold.		2	T 3200 002	T 3200 028	T 3200 552 ⁴⁾
				3 DIN	T 3260 002	T 3260 028	T 3260 552
				4 IEC	T 3300 002	T 3300 028	T 3300 552
5	T 3360 002			T 3360 028	T 3360 552		
5 S DIN	T 3360 020			T 3356 028 ⁴⁾	T 3356 552 ⁴⁾		
6 DIN	T 3400 002			T 3400 028	T 3400 552		
7	T 3475 002			T 3475 028	T 3475 552		
7 DIN	T 3484 002			T 3484 028	T 3484 552		
8 DIN	T 3504 002			T 3504 028	T 3504 552 ⁴⁾		
12	–			T 3635 002	–		
14	–			T 3650 002	–		
Male cable connector, max. cable outlet 6.5 mm, termination: solder or crimp, contact plating: silver or gold.				2	T 3200 004	T 3200 048	–
				3 DIN	T 3260 004	T 3260 048	T 3260 554
				4 IEC	T 3300 004	T 3300 048	T 3300 554 ⁴⁾
		5	T 3360 004	T 3360 048	T 3360 554 ⁴⁾		
		5 S DIN	T 3356 004	T 3356 048 ⁴⁾	T 3356 554		
		6 DIN	T 3400 004	T 3400 048	T 3400 554 ⁴⁾		
		7	T 3475 004	T 3475 048	T 3475 554 ⁴⁾		
		7 DIN	T 3484 004	T 3484 048	T 3484 554 ⁴⁾		
		8 DIN	T 3504 004	T 3504 048	T 3504 554 ⁴⁾		
		12	–	T 3635 004	–		
		14	–	T 3650 004	–		
		Male cable connector, max. cable outlet 6 mm, solder termination, plastic coated coupling ring, contact plating: silver.		2	T 3200 013	–	–
				3 DIN	T 3260 013	–	–
				4 IEC	T 3300 013	–	–
5	T 3360 013			–	–		
5 S DIN	T 3360 130			–	–		
6 DIN	T 3400 013			–	–		
7	T 3475 013			–	–		
7 DIN	T 3484 013 ⁴⁾			–	–		
8 DIN	T 3504 013			–	–		
12	–			–	–		
14	–			–	–		

¹⁾ Please order crimp contacts separately, see page 46 ²⁾ see remark page 9

⁴⁾ Available upon request. Min. order qty. 100 pcs/type.

C 091 A

Male cable connector,
screw locking,
right-angled



Description	Drawing	No. of cont.	Part Number solder termination		Part Number Crimp termination ¹⁾
			Contact plating silver	Contact plating gold ²⁾	
Male cable connector, right-angled, max. cable outlet 6 mm, termination: solder or crimp, contact plating: silver or gold.		2	T 3200 005	T 3200 058 ⁴⁾	—
		3 DIN	T 3260 005	T 3260 058 ⁴⁾	T 3260 055 ⁴⁾
		4 IEC	T 3300 005	T 3300 058 ⁴⁾	T 3300 055 ⁴⁾
		5	T 3360 005	T 3360 058	T 3360 055
		5 S DIN	T 3356 005	T 3356 058 ⁴⁾	T 3356 055 ⁴⁾
		6 DIN	T 3400 005	T 3400 058	T 3400 055
		7	T 3475 005	T 3475 058 ⁴⁾	T 3475 055 ⁴⁾
		7 DIN	T 3484 005	T 3484 058 ⁴⁾	T 3484 055 ⁴⁾
		8 DIN	T 3504 005	T 3504 058 ⁴⁾	T 3504 055 ⁴⁾
		12	T 3635 005	T 3635 058	—
		14	T 3650 005	T 3650 058	—

¹⁾ Please order crimp contacts separately, see page 46 ²⁾ See remark page 9

⁴⁾ Available upon request. Min. order qty. 100 pcs/type.

Assembling instruction male cable connector, max. cable outlet 6 mm	Assembling instruction male cable connector, max. cable outlet 6.5 mm or 8 mm
Assembling instruction male cable connector, right-angled	

C 091 A

Female cable connector,
screw locking,
straight



Cable outlet 6 mm



Cable outlet 8 mm



Cable outlet 6.5 mm



Cable outlet 6 mm

Description	Drawing	No. of cont.	Part Number solder termination		Part Number Crimp termination ¹⁾		
			Contact plating silver	Contact plating gold ²⁾			
Female cable connector, max. cable outlet 6 mm, termination: solder or crimp, contact plating: silver or gold.		2	T 3201 001	T 3201 018	–		
		3 DIN	T 3261 001	T 3261 018	T 3261 551		
		4 IEC	T 3301 001	T 3301 018	T 3301 551		
		5	T 3361 001	T 3361 018	T 3361 551		
		5 S DIN	T 3361 010	T 3357 018 ⁴⁾	T 3357 551		
		6 DIN	T 3401 001	T 3401 018	T 3401 551		
		7	T 3476 001	T 3476 018	T 3476 551		
		7 DIN	T 3485 001	T 3485 018	T 3485 551 ⁴⁾		
		8 DIN	T 3505 001	T 3505 018	T 3505 551		
		12	T 3636 001	T 3636 000	–		
		14	T 3651 001	T 3651 000	–		
		Female cable connector, max. cable outlet 8 mm, termination: solder or crimp, contact plating: silver or gold.		2	T 3201 002	T 3201 028	–
				3 DIN	T 3261 002	T 3261 028	T 3261 552 ⁴⁾
				4 IEC	T 3301 002	T 3301 028	T 3301 552 ⁴⁾
5	T 3361 002			T 3361 028	T 3361 552 ⁴⁾		
5 S DIN	T 3361 020			T 3357 028 ⁴⁾	T 3357 552 ⁴⁾		
6 DIN	T 3401 002			T 3401 028	T 3401 552 ⁴⁾		
7	T 3476 002			T 3476 028	T 3476 552		
7 DIN	T 3485 002			T 3485 028	T 3485 552 ⁴⁾		
8 DIN	T 3505 002			T 3505 028	T 3505 552 ⁴⁾		
12	–			T 3636 002	–		
14	–			T 3651 002	–		
Female cable connector, max. cable outlet 6.5 mm, termination: solder or crimp, contact plating: silver or gold.				2	T 3201 004 ⁴⁾	T 3201 048 ⁴⁾	–
				3 DIN	T 3261 004	T 3261 048	T 3261 554 ⁴⁾
				4 IEC	T 3301 004	T 3301 048	T 3301 554
		5	T 3361 004	T 3361 048 ⁴⁾	T 3361 554 ⁴⁾		
		5 S DIN	T 3357 004	T 3357 048 ⁴⁾	T 3357 554		
		6 DIN	T 3401 004	T 3401 048	T 3401 554 ⁴⁾		
		7	T 3476 004	T 3476 048	T 3476 554 ⁴⁾		
		7 DIN	T 3485 004	T 3485 048	T 3485 554 ⁴⁾		
		8 DIN	T 3505 004	T 3505 048	T 3505 554		
		12	–	T 3636 004	–		
		14	–	T 3651 004	–		
		Female cable connector, max. cable outlet 6 mm, solder termination, plastic coated coupling ring, contact plating: silver.		2	T 3201 013	–	–
				3 DIN	T 3261 013	–	–
				4 IEC	T 3301 013	–	–
5	T 3361 013			–	–		
5 S DIN	T 3361 130			–	–		
6 DIN	T 3401 013			–	–		
7	T 3476 013			–	–		
7 DIN	T 3485 013			–	–		
8 DIN	T 3505 013			–	–		
12	–			–	–		
14	–			–	–		

¹⁾ Please order crimp contacts separately, see page 46 ²⁾ See remark page 9

⁴⁾ Available upon request. Min. order qty.100 pcs/type.

C 091 A

Female cable connector,
screw locking,
right-angled



Description	Drawing	No. of cont.	Part Number solder termination		Part Number Crimp termination ¹⁾
			Contact plating silver	Contact plating gold ²⁾	
Female cable connector, right-angled, max. cable outlet 6 mm, termination: solder or crimp, contact plating: silver or gold.		2	T 3201 005	T 3201 058 ⁴⁾	—
		3 DIN	T 3261 005	T 3261 058 ⁴⁾	T 3261 055 ⁴⁾
		4 IEC	T 3301 005	T 3301 058 ⁴⁾	T 3301 055 ⁴⁾
		5	T 3361 005	T 3361 058 ⁴⁾	T 3361 055 ⁴⁾
		5 S DIN	T 3357 005	T 3357 058	T 3357 055 ⁴⁾
		6 DIN	T 3401 005	T 3401 058	T 3401 055
		7	T 3476 005	T 3476 058 ⁴⁾	T 3476 055 ⁴⁾
		7 DIN	T 3485 005	T 3485 058 ⁴⁾	T 3485 055 ⁴⁾
		8 DIN	T 3505 005	T 3505 058 ⁴⁾	T 3505 055 ⁴⁾
		12	T 3636 005	T 3636 058	—
		14	T 3651 005	T 3651 058 ⁴⁾	—

¹⁾ Please order crimp contacts separately, see page 46 ²⁾ See remark page 9

⁴⁾ Available upon request. Min. order qty.100 pcs/type.

Assembling instruction female cable connector, max. cable outlet 6 mm	Assembling instruction female cable connector, max. cable outlet 6.5 mm or 8 mm
Assembling instruction female cable connector, right-angled	

C 091 A

Female receptacle,
screw locking,
front mounting

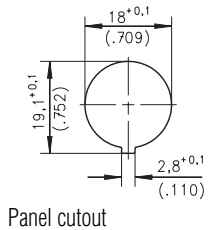
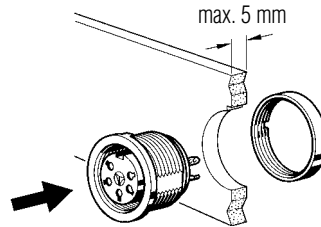

Panel cutout

Description	Drawing	No. of cont.	Part Number solder termination			Part No. Crimp termination ¹⁾		
			Contact plating silver ring nut	hex nut	Contact plating gold ²⁾ ring nut			
Female receptacle, termination: solder or crimp, panel mounting with ring or hex nut, contact plating: silver or gold. solder area: tin plated		2	T 3203 000	T 3203 009	T 3203 018	–		
		3 DIN	T 3263 000	T 3263 009	T 3263 018	T 3263 550		
		4 IEC	T 3303 000	T 3303 009	T 3303 018	T 3303 550		
		5	T 3363 000	T 3363 009	T 3363 018	T 3363 550		
		5 S DIN	T 3363 010	T 3359 009	T 3359 018	T 3359 550		
		6 DIN	T 3403 000	T 3403 009	T 3403 018	T 3403 550		
		7	T 3478 000	T 3478 009	T 3478 018	T 3478 550		
		7 DIN	T 3487 000	T 3487 009	T 3487 018 ⁴⁾	T 3487 550		
		8 DIN	T 3507 000	T 3507 009	T 3507 018	T 3507 550 ⁴⁾		
		12	T 3638 000	T 3638 009	T 3638 004	–		
		14	T 3653 000	T 3653 009	T 3653 004	–		
		Female receptacle, termination: straight dip solder, pin length 15 mm from flange, panel mounting with ring nut, contact plating: silver or gold. solder area: tin plated		2	T 3203 300 ⁴⁾	–	–	–
				3 DIN	T 3263 300	–	–	–
				4 IEC	T 3303 300	–	–	–
5	T 3363 300			–	–	–		
5 S DIN	T 3359 300			–	–	–		
6 DIN	T 3403 300			–	–	–		
7	T 3478 300			–	–	–		
7 DIN	T 3487 300			–	–	–		
8 DIN	T 3507 300			–	–	–		
12	–			–	T 3638 304	–		
14	–			–	T 3653 304 ⁴⁾	–		
Female receptacle, termination: straight dip solder, pin length 19 mm from flange, panel mounting with ring nut, contact plating: silver. solder area: tin plated				2	T 3203 320 ⁴⁾	–	–	–
				3 DIN	T 3263 320	–	–	–
				4 IEC	T 3303 320	–	–	–
		5	T 3363 320	–	–	–		
		5 S DIN	T 3359 320	–	–	–		
		6 DIN	T 3403 320	–	–	–		
		7	T 3478 320	–	–	–		
		7 DIN	T 3487 320	–	–	–		
		8 DIN	T 3507 320	–	–	–		
		12	–	–	–	–		
		14	–	–	–	–		
		Female receptacle, termination: straight dip solder, pin length 24 mm from flange, panel mounting with ring nut, contact plating: silver. solder area: tin plated		2	T 3203 330 ⁴⁾	–	–	–
				3 DIN	T 3263 330	–	–	–
				4 IEC	T 3303 330	–	–	–
5	T 3363 330			–	–	–		
5 S DIN	T 3359 330			–	–	–		
6 DIN	T 3403 330			–	–	–		
7	T 3478 330			–	–	–		
7 DIN	T 3487 330			–	–	–		
8 DIN	T 3507 330			–	–	–		
12	–			–	–	–		
14	–			–	–	–		

¹⁾ Please order crimp contacts separately, see page 46 ²⁾ See remark page 9

⁴⁾ Available upon request. Min. order qty.100 pcs/type.

C 091 A

Female receptacle,
screw locking,
rear mounting

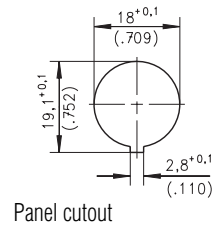
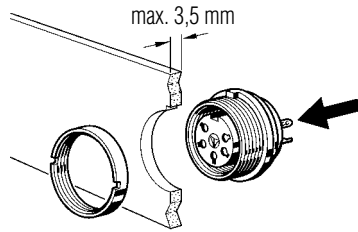

Panel cutout

Description	Drawing	No. of cont.	Part Number solder termination			Part No. Crimp termination ¹⁾ ring nut		
			Contact plating silver ring nut	hex nut	Contact plating gold ²⁾ ring nut			
Female receptacle, termination: solder or crimp, panel mounting with ring or hex nut, contact plating: silver or gold. solder area: tin plated	<p>*Measure 12- and 14-pol.=10±0,3</p>	2	T 3203 100	T 3203 109 ⁴⁾	T 3203 118 ⁴⁾	—		
		3 DIN	T 3263 100	T 3263 109 ⁴⁾	T 3263 118 ⁴⁾	T 3263 150 ⁴⁾		
		4 IEC	T 3303 100	T 3303 109 ⁴⁾	T 3303 118	T 3303 150		
		5	T 3363 100	T 3363 109	T 3363 118 ⁴⁾	T 3363 150		
		5 S DIN	T 3359 100	T 3359 109	T 3359 118 ⁴⁾	T 3359 150		
		6 DIN	T 3403 100	T 3403 109	T 3403 118 ⁴⁾	T 3403 150		
		7	T 3478 100	T 3478 109 ⁴⁾	T 3478 118	T 3478 150		
		7 DIN	T 3487 100	T 3487 109 ⁴⁾	T 3487 118 ⁴⁾	T 3487 150 ⁴⁾		
		8 DIN	T 3507 100	T 3507 109	T 3507 118	T 3507 150		
		12	T 3638 100	T 3638 109 ⁴⁾	T 3638 118 ⁴⁾	—		
		14	T 3653 100	T 3653 109 ⁴⁾	T 3653 118	—		
		Female receptacle, termination: straight dip solder, pin length 10.5 mm from flange, panel mounting with ring nut, contact plating: silver or gold. solder area: tin plated	<p>*Measure 12- and 14-pol. Ø 0,6</p>	2	T 3203 400	—	—	—
				3 DIN	T 3263 400	—	—	—
				4 IEC	T 3303 400	—	—	—
5	T 3363 400			—	—	—		
5 S DIN	T 3359 400			—	—	—		
6 DIN	T 3403 400			—	—	—		
7	T 3478 400			—	—	—		
7 DIN	T 3487 400			—	—	—		
8 DIN	T 3507 400			—	—	—		
12	—			—	T 3638 404	—		
14	—			—	T 3653 404	—		
Female receptacle, termination: straight dip solder, pin length 14.5 mm from flange, panel mounting with ring nut, contact plating: silver. solder area: tin plated				2	T 3203 420 ⁴⁾	—	—	—
				3 DIN	T 3263 420	—	—	—
				4 IEC	T 3303 420	—	—	—
		5	T 3363 420	—	—	—		
		5 S DIN	T 3359 420	—	—	—		
		6 DIN	T 3403 420	—	—	—		
		7	T 3478 420	—	—	—		
		7 DIN	T 3487 420	—	—	—		
		8 DIN	T 3507 420	—	—	—		
		12	—	—	—	—		
		14	—	—	—	—		
		Female receptacle, termination: straight dip solder, pin length 19.5 mm from flange, panel mounting with ring nut, contact plating: silver. solder area: tin plated		2	T 3203 430 ⁴⁾	—	—	—
				3 DIN	T 3263 430	—	—	—
				4 IEC	T 3303 430	—	—	—
5	T 3363 430			—	—	—		
5 S DIN	T 3359 430			—	—	—		
6 DIN	T 3403 430			—	—	—		
7	T 3478 430			—	—	—		
7 DIN	T 3487 430			—	—	—		
8 DIN	T 3507 430			—	—	—		
12	—			—	—	—		
14	—			—	—	—		

¹⁾ Please order crimp contacts separately, see page 46 ²⁾ See remark page 9

⁴⁾ Available upon request. Min. order qty.100 pcs/type.

C 091 A

Female receptacle,
screw locking,
right-angled

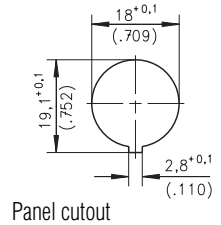

Description	Drawing	No. of cont.	Part Number solder termination		Part Number Crimp termination ¹⁾			
			Contact plating silver	Contact plating gold ²⁾				
Female receptacle, right-angled, PCB mounting, contact plating: gold solder area: tin plated	 <table border="1"> <tr><th>* A Part No.</th></tr> <tr><td>3 ...218</td></tr> <tr><td>8.3 ...228</td></tr> </table> 	* A Part No.	3 ...218	8.3 ...228	2	-	-	-
		* A Part No.						
		3 ...218						
		8.3 ...228						
		3 DIN	-	-	-			
		4 IEC	-	-	-			
		5	-	T 3363 ... ³⁾	-			
		5 S DIN	-	-	-			
		6 DIN	-	T 3403 ... ³⁾	-			
		7	-	-	-			
		7 DIN	-	-	-			
		8 DIN	-	-	-			
		12	-	-	-			
		14	-	-	-			
PCB-layout		5 POL.	-	-	-			
		6 POL.	-	-	-			
Female receptacle, right-angled, rear mounting, panel mounting with ring nut, contact plating: gold. solder area: tin plated		2	-	-	-			
		3 DIN	-	-	-			
		4 IEC	-	-	-			
		5	-	T 3363 902	-			
		5 S DIN	-	-	-			
		6 DIN	-	T 3403 902	-			
		7	-	-	-			
		7 DIN	-	-	-			
		8 DIN	-	-	-			
		12	-	-	-			
		14	-	-	-			
		PCB-layout		5 POL	-	-	-	
				6 POL	-	-	-	
					-	-	-	

C 091 A

Female receptacle,
screw locking,
right-angled

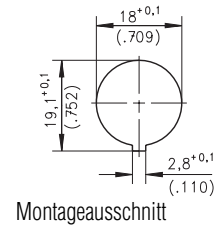

Description	Drawing	No. of cont.	Part Number solder termination		Part Number Crimp termination ¹⁾
			Contact plating silver	Contact plating gold ²⁾	
Female receptacle, right-angled, PCB mounting, contact plating: silver solder area: tin plated		2	-	-	-
		3 DIN	T 3263 900	-	-
		4 IEC	-	-	-
		5	-	-	-
		5 S DIN	T 3359 900	-	-
		6 DIN	-	-	-
		7	-	-	-
		7 DIN	T 3487 900	-	-
		8 DIN	T 3507 900	-	-
		12	-	-	-
14	-	-	-		

Hole pattern on PCB

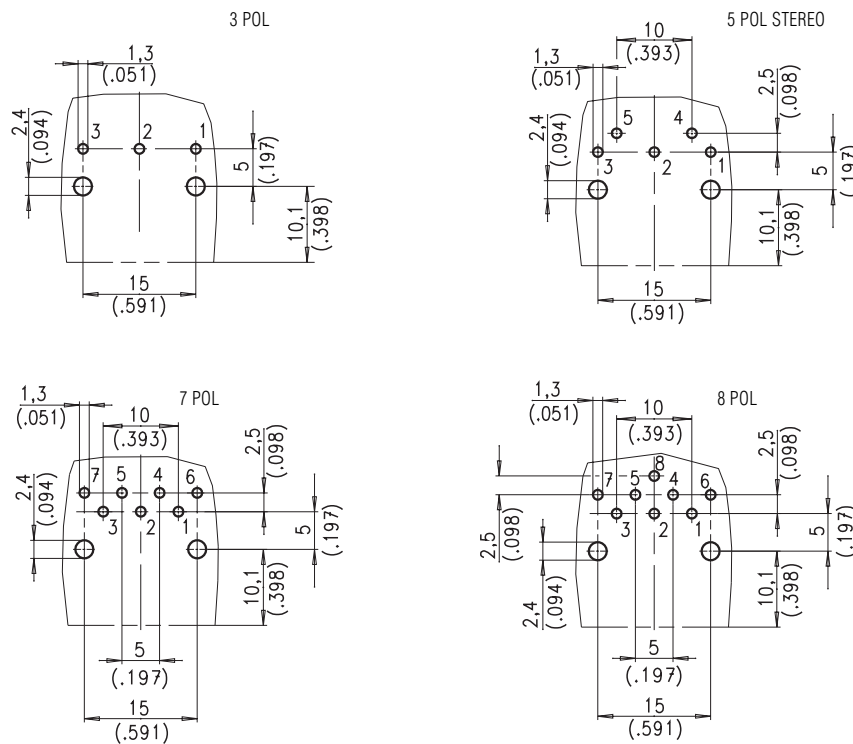

¹⁾ Please order crimp contacts separately, see page 46 ²⁾ see remark page 9

C 091 A

Male receptacle,
screw locking,
front mounting

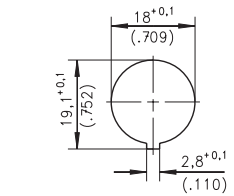
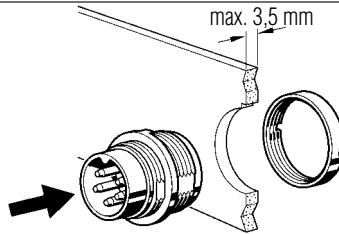

Panel cutout

Description	Drawing	No. of cont.	Part Number solder termination			Part No. Crimp termination ¹⁾ ring nut		
			Contact plating silver ring nut	hex nut	Contact plating gold ²⁾ ring nut			
Male receptacle, termination: solder or crimp, panel mounting with ring or hex nut, contact plating: silver or gold. solder area: tin plated		2	T 3202 000	T 3202 009	T 3202 018	–		
		3 DIN	T 3262 000	T 3262 009	T 3262 018	T 3262 550		
		4 IEC	T 3302 000	T 3302 009	T 3302 018	T 3302 550		
		5	T 3362 000	T 3362 009	T 3362 018	T 3362 550		
		5 S DIN	T 3362 010	T 3358 009	T 3358 018 ⁴⁾	T 3358 550 ⁴⁾		
		6 DIN	T 3402 000	T 3402 009	T 3402 018	T 3402 550		
		7	T 3477 000	T 3477 009	T 3477 018	T 3477 550		
		7 DIN	T 3486 000	T 3486 009	T 3486 018	T 3486 550 ⁴⁾		
		8 DIN	T 3506 000	T 3506 009	T 3506 018	T 3506 550 ⁴⁾		
		12	T 3637 001	T 3637 009	T 3637 000	–		
		14	T 3652 001	T 3652 009	T 3652 000	–		
		Male receptacle, termination: straight dip solder, pin length 10.5 mm from flange, panel mounting with ring nut, contact plating: silver or gold. solder area: tin plated		2	T 3202 300 ⁴⁾	–	–	–
				3 DIN	T 3262 300	–	–	–
				4 IEC	T 3302 300 ⁴⁾	–	–	–
5	T 3362 300 ⁴⁾			–	–	–		
5 S DIN	T 3358 300 ⁴⁾			–	–	–		
6 DIN	T 3402 300 ⁴⁾			–	–	–		
7	T 3477 300 ⁴⁾			–	–	–		
7 DIN	T 3486 300 ⁴⁾			–	–	–		
8 DIN	T 3506 300 ⁴⁾			–	–	–		
12	–			–	T 3637 304 ⁴⁾	–		
14	–	–	T 3652 304 ⁴⁾	–				

¹⁾ Please order crimp contacts separately, see page 46 ²⁾ see remark page 9

⁴⁾ Available upon request. Min. order qty. 100 pcs/type.

C 091 A

Male receptacle,
screw locking,
rear mounting

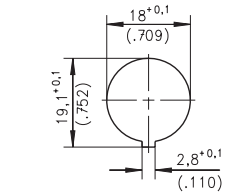
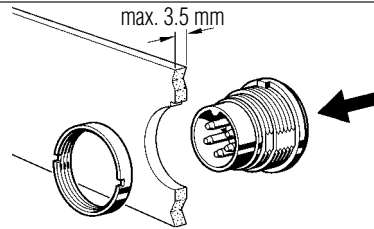

Panel cutout

Description	Drawing	No. of cont.	Part Number solder termination			Part No. Crimp termination ¹⁾ ring nut		
			Contact plating silver ring nut	hex nut	Contact plating gold ²⁾ ring nut			
Male receptacle, termination: solder or crimp, panel mounting with ring nut, contact plating: silver or gold. solder area: tin plated		2	T 3202 100	–	–	–		
		3 DIN	T 3262 100	–	–	T 3262 150 ⁴⁾		
		4 IEC	T 3302 100	–	–	T 3302 150 ⁴⁾		
		5	T 3362 100	–	–	T 3362 150		
		5 S DIN	T 3358 100	–	–	T 3358 150 ⁴⁾		
		6 DIN	T 3402 100	–	–	T 3402 150 ⁴⁾		
		7	T 3477 100	–	–	T 3477 150 ⁴⁾		
		7 DIN	T 3486 100	–	–	T 3486 150 ⁴⁾		
		8 DIN	T 3506 100	–	–	T 3506 150 ⁴⁾		
		12	–	–	T 3637 100	–		
		14	–	–	T 3652 100	–		
		Male receptacle, termination: straight dip solder, pin length 6 mm from flange, panel mounting with ring nut, contact plating: silver or gold. solder area: tin plated		2	T 3202 400 ⁴⁾	–	–	–
				3 DIN	T 3262 400	–	–	–
				4 IEC	T 3302 400 ⁴⁾	–	–	–
5	T 3362 400			–	–	–		
5 S DIN	T 3358 400 ⁴⁾			–	–	–		
6 DIN	T 3402 400 ⁴⁾			–	–	–		
7	T 3477 400			–	–	–		
7 DIN	T 3486 400 ⁴⁾			–	–	–		
8 DIN	T 3506 400 ⁴⁾			–	–	–		
12	–			–	T 3637 404	–		
14	–	–	T 3652 404 ⁴⁾	–				

¹⁾ Please order crimp contacts separately, see page 46 ²⁾ see remark page 9

⁴⁾ Available upon request. Min. order qty. 100 pcs/type.

PCB-layout

These hole patterns on PCB are valid for all receptacles with **straight dip solder pins**.

3 POL
DIN 41 524

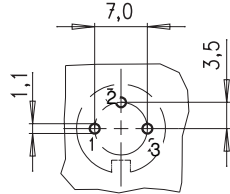

4 POL
IEC130 - 9

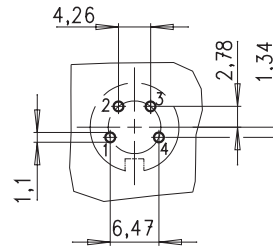

5 POL
DIN 45 322

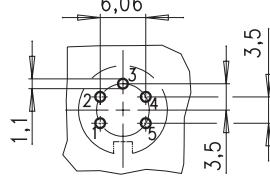

5 POL STEREO
DIN 41 524

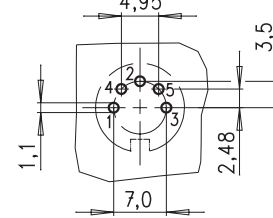

6 POL
DIN 45 322

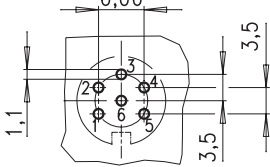

7 POL

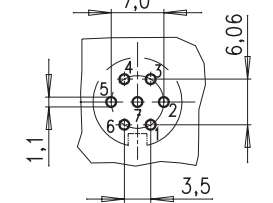

7 POL
DIN 45 329

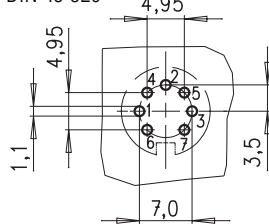

8 POL
DIN 45 326

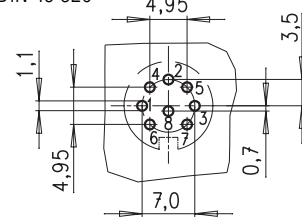

12 POL

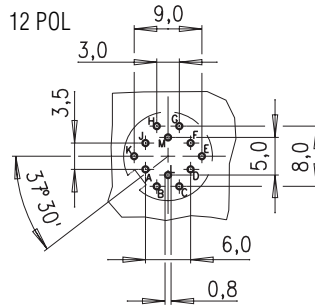

14 POL

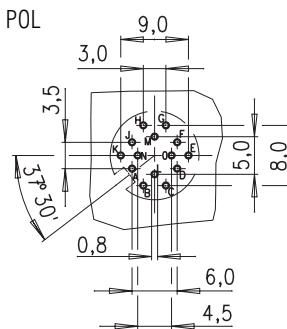

C 091 B



Main Features











- Bayonet locking.
- Number of contacts are 3 to 8, 12 and 14.
- Internal metal strain relief with half shell construction and snap-in latching. Plastic strain relief also available.
- Complete EMI shielding in fully mated and locked position.
- Male and female cable connectors: solder in 3 to 8, 12, 14 positions; crimp in 3 to 8 positions; cable outlet PG 7 for diameter of 6 mm; cable outlet PG 9 for diameters of 6.5 mm and 8 mm; cable entry straight or right-angled.
- Male and female receptacles for panel mount: front mounting; solder in 3 to 8, 12, 14 positions; crimp in 3 to 8 positions; PCB mounting in right-angled, vertical mounting upon request, using dip solder termination.
- Colored back-shells for coding, see page 47.
- The connectors are registered under File # E 63 093 UL.



UNDERWRITERS LABORATORIES INC.

C 091 B

Characteristics

General Characteristics	Standard	Characteristics									
Number of contacts		3	4	5	5 Stereo	6	7	7	8	12	14
View on termination side of contact insert											
Contact arrangement acc. to DIN		41 524	–	–	41 524	41 322	–	45 329	45 326	–	–
Contact arrangement acc. to IEC		130-9	–	–	130-9	130-9	–	130-9	130-9	–	–
Electrical Characteristics											
Rated voltage	IEC 60664-1	300 V ≈			100 V ≈	300 V ≈			150 V ≈		
Rated impulse withstand voltage	IEC 60664-1	1500 V			1200 V	1500 V			1200 V		
Pollution degree	IEC 60664-1	1									
Installation category	IEC 60664-1	I									
Insulation group	IEC 60664-1	3									
Test voltage	IEC 60664-1	980 V ~			670 V ~	980 V ~			670 V ~		
Current rating	IEC 60512-3 Test 5 b	5 A / + 40 °C / + 104 °F								3 A / + 40 °C / + 104 °F	
Insulation resistance	IEC 60512-2 Test 3 a	> 10 ¹² Ω									
Contact resistance	IEC 60512-2 Test 2 a	< 5 m Ω									
Climatical Characteristics											
Climatic category	IEC 60668-1	40 / 85 / 56									
Temperature range	IEC 60668-1	- 40 °C ... + 85 °C / - 40 °F ... + 185 °F									
Mechanical Characteristics											
IP-degree	IEC 60529	IP 40									
Insertion and withdrawal forces	IEC 60512-7 Test 13 b	25 N 90.oz	30 N 110.oz	35 N 125.oz	50 N 180.oz	55 N 200.oz	60 N 220.oz	60 N 220.oz	50 N 180.oz		
Mechanical operation	IEC 60512-5 Test 9 a	Silver ≥ 500 mating cycles Gold ≥ 1000 mating cycles									
Materials											
Housing material		die cast, nickel plated									
Dielectric material		thermoplastic									
Contact plating		silver plated / gold plated *									
Further Characteristics											
Termination technique		solder, crimp								solder	
Wire gauge		solder ≤ 0,5 mm ² (20-26 AWG), crimp 0,14 – 1,0 mm ² (26-18 AWG)								≤ 0,25 mm/24 AWG	
Flammability		UL 94 V0									
Locking system		bayonet									

Characteristics

Do not connect or disconnect under load. Metal housing parts shall be securely incorporated to protected ground.

* Remark for gold plated contacts

To avoid brittle intermetallic connections gold-plated soldering terminals must be pre-tinned before soldering.

C 091 B

Male cable connector, bayonet locking inside



cable outlet 6 mm



cable outlet 8 mm



cable outlet 6.5 mm



right-angled

Description	Drawing	No. of cont.	Part Number solder termination		Part Number Crimp termination ¹⁾
			Contact plating silver	Contact plating gold ²⁾	
Male cable connector, max. cable outlet 6 mm, termination: solder or crimp, contact plating: silver or gold.		3 DIN	T 3274 501	T 3274 518	T 3274 551
		4 IEC	T 3324 501	T 3324 518	T 3324 551
		5	T 3374 501	T 3374 518	T 3374 551
		5 S DIN	T 3394 501	T 3394 518	T 3394 551
		6 DIN	T 3424 501	T 3424 518	T 3424 551
		7	T 3434 501	T 3434 518 ⁴⁾	T 3434 551
		7 DIN	T 3444 501 ⁴⁾	T 3444 518 ⁴⁾	T 3444 551 ⁴⁾
		8 DIN	T 3524 501	T 3524 518 ⁴⁾	T 3524 551
		12	T 3624 501	T 3624 518 ⁴⁾	—
		14	T 3644 501 ⁴⁾	T 3644 518 ⁴⁾	—
		Male cable connector, max. cable outlet 8 mm, termination: solder or crimp, contact plating: silver or gold.		3 DIN	T 3274 502
4 IEC	T 3324 502			T 3324 528 ⁴⁾	T 3324 552
5	T 3374 502			T 3374 528 ⁴⁾	T 3374 552
5 S DIN	T 3394 502			T 3394 528 ⁴⁾	T 3394 552 ⁴⁾
6 DIN	T 3424 502			T 3424 528 ⁴⁾	T 3424 552
7	T 3434 502			T 3434 528 ⁴⁾	T 3434 552
7 DIN	T 3444 502 ⁴⁾			T 3444 528 ⁴⁾	T 3444 552 ⁴⁾
8 DIN	T 3524 502			T 3524 528 ⁴⁾	T 3524 552 ⁴⁾
12	T 3624 502			T 3624 528 ⁴⁾	—
14	T 3644 502			T 3644 528 ⁴⁾	—
Male cable connector, max. cable outlet 6.5 mm, termination: solder or crimp, contact plating: silver or gold.				3 DIN	T 3274 504 ⁴⁾
		4 IEC	T 3324 504 ⁴⁾	T 3324 548 ⁴⁾	T 3324 554 ⁴⁾
		5	T 3374 504 ⁴⁾	T 3374 548 ⁴⁾	T 3374 554 ⁴⁾
		5 S DIN	T 3394 504 ⁴⁾	T 3394 548 ⁴⁾	T 3394 554 ⁴⁾
		6 DIN	T 3424 504 ⁴⁾	T 3424 548 ⁴⁾	T 3424 554 ⁴⁾
		7	T 3434 504 ⁴⁾	T 3434 548 ⁴⁾	T 3434 554 ⁴⁾
		7 DIN	T 3444 504 ⁴⁾	T 3444 548 ⁴⁾	T 3444 554 ⁴⁾
		8 DIN	T 3524 504 ⁴⁾	T 3524 548 ⁴⁾	T 3524 554 ⁴⁾
		12	T 3624 504 ⁴⁾	T 3624 548 ⁴⁾	—
		14	T 3644 504 ⁴⁾	T 3644 548 ⁴⁾	—
		Male cable connector, right-angled, max. cable outlet 6 mm, termination: solder or crimp, contact plating: silver or gold.		3 DIN	T 3274 005
4 IEC	T 3324 005			T 3324 058 ⁴⁾	T 3324 055 ⁴⁾
5	T 3374 005			T 3374 058	T 3374 055
5 S DIN	T 3394 005			T 3394 058 ⁴⁾	T 3394 055 ⁴⁾
6 DIN	T 3424 005			T 3424 058 ⁴⁾	T 3424 055
7	T 3434 005			T 3434 058 ⁴⁾	T 3434 055 ⁴⁾
7 DIN	T 3444 005 ⁴⁾			T 3444 058 ⁴⁾	T 3444 055 ⁴⁾
8 DIN	T 3524 005			T 3524 058 ⁴⁾	T 3524 055 ⁴⁾
12	T 3624 005			T 3624 058 ⁴⁾	—
14	T 3644 005			T 3644 058 ⁴⁾	—

¹⁾ Please order crimp contacts separately, see page 46 ²⁾ see remark page 23

⁴⁾ Available upon request. Min. order qty. 100 pcs/type.

C 091 B

Male cable connector,
bayonet locking inside,
assembling instructions

Male cable connector, max. cable outlet 6 mm

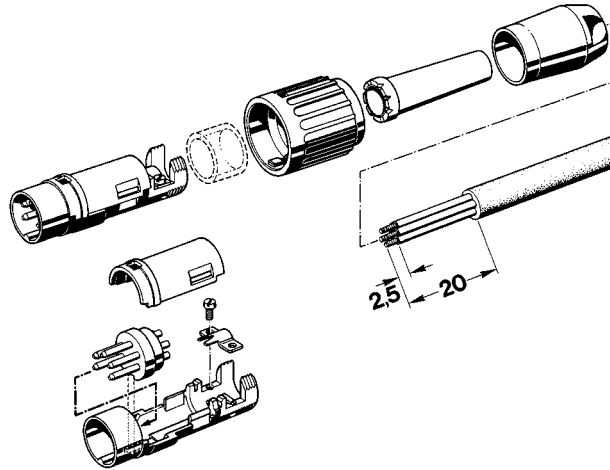

Male cable connector, max. cable outlet 6.5 mm or 8 mm

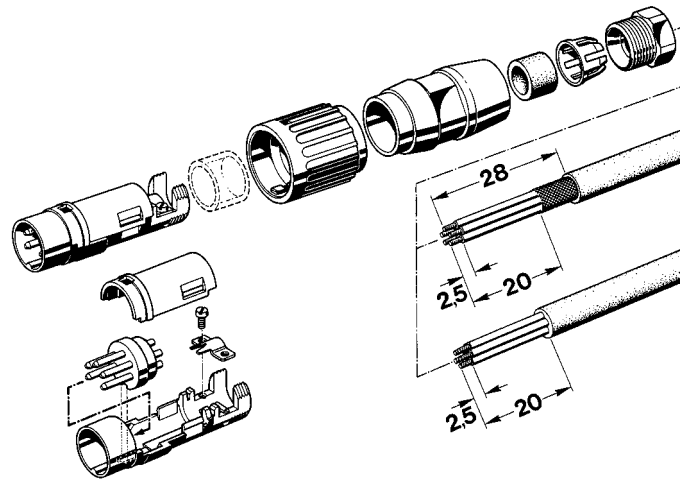

Male cable connector, right-angled

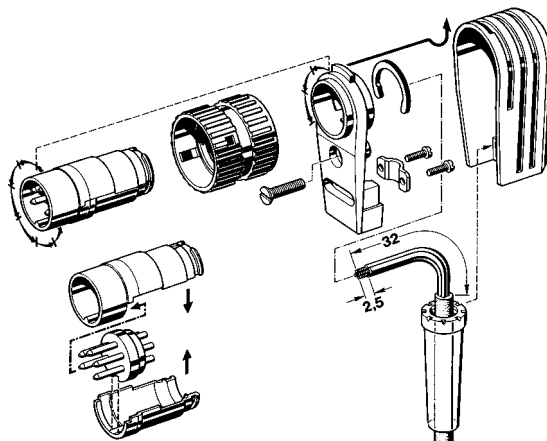

C 091 B

Male cable connector,
bayonet locking outside



cable outlet 6 mm



cable outlet 8 mm



cable outlet 6.5 mm

Description	Drawing	No. of cont.	Part Number solder termination		Part Number Crimp termination ¹⁾
			Contact plating silver	Contact plating gold ²⁾	
Male cable connector, max. cable outlet 6 mm, termination: solder or crimp, contact plating: silver or gold.		3 DIN	T 3279 501	T 3279 518 ⁴⁾	T 3279 551
		4 IEC	T 3329 501	T 3329 518 ⁴⁾	T 3329 551
		5	T 3379 501	T 3379 518 ⁴⁾	T 3379 551
		5 S DIN	T 3399 501	T 3399 518 ⁴⁾	T 3399 551 ⁴⁾
		6 DIN	T 3429 501	T 3429 518 ⁴⁾	T 3429 551
		7	T 3439 501	T 3439 518 ⁴⁾	T 3439 551
		7 DIN	T 3449 501 ⁴⁾	T 3449 518 ⁴⁾	T 3449 551 ⁴⁾
		8 DIN	T 3529 501 ⁴⁾	T 3529 518 ⁴⁾	T 3529 551 ⁴⁾
		12	T 3629 501 ⁴⁾	T 3629 518 ⁴⁾	—
		14	T 3649 501 ⁴⁾	T 3649 518 ⁴⁾	—
		Male cable connector, max. cable outlet 8 mm, termination: solder or crimp, contact plating: silver or gold.		3 DIN	T 3279 502
4 IEC	T 3329 502			T 3329 528 ⁴⁾	T 3329 552
5	T 3379 502			T 3379 528 ⁴⁾	T 3379 552
5 S DIN	T 3399 502			T 3399 528 ⁴⁾	T 3399 552 ⁴⁾
6 DIN	T 3429 502			T 3429 528 ⁴⁾	T 3429 552
7	T 3439 502			T 3439 528 ⁴⁾	T 3439 552
7 DIN	T 3449 502 ⁴⁾			T 3449 528 ⁴⁾	T 3449 552 ⁴⁾
8 DIN	T 3529 502 ⁴⁾			T 3529 528 ⁴⁾	T 3529 552 ⁴⁾
12	T 3629 502 ⁴⁾			T 3629 528 ⁴⁾	—
14	T 3649 502 ⁴⁾			T 3649 528 ⁴⁾	—
Male cable connector, max. cable outlet 6.5 mm, termination: solder or crimp, contact plating: silver or gold.				3 DIN	T 3279 504 ⁴⁾
		4 IEC	T 3329 504 ⁴⁾	T 3329 548 ⁴⁾	T 3329 554 ⁴⁾
		5	T 3379 504 ⁴⁾	T 3379 548 ⁴⁾	T 3379 554 ⁴⁾
		5 S DIN	T 3399 504 ⁴⁾	T 3399 548 ⁴⁾	T 3399 554 ⁴⁾
		6 DIN	T 3429 504 ⁴⁾	T 3429 548 ⁴⁾	T 3429 554 ⁴⁾
		7	T 3439 504 ⁴⁾	T 3439 548 ⁴⁾	T 3439 554 ⁴⁾
		7 DIN	T 3449 504 ⁴⁾	T 3449 548 ⁴⁾	T 3449 554 ⁴⁾
		8 DIN	T 3529 504 ⁴⁾	T 3529 548 ⁴⁾	T 3529 554 ⁴⁾
		12	T 3629 504 ⁴⁾	T 3629 548 ⁴⁾	—
		14	T 3649 504 ⁴⁾	T 3649 548 ⁴⁾	—

¹⁾ Please order crimp contacts separately, see page 46 ²⁾ see remark page 23

⁴⁾ Available upon request. Min. order qty. 100 pcs/type.

C 091 B

Male cable connector,
bayonet locking outside,
assembling instructions

Male cable connector, max. cable outlet 6 mm

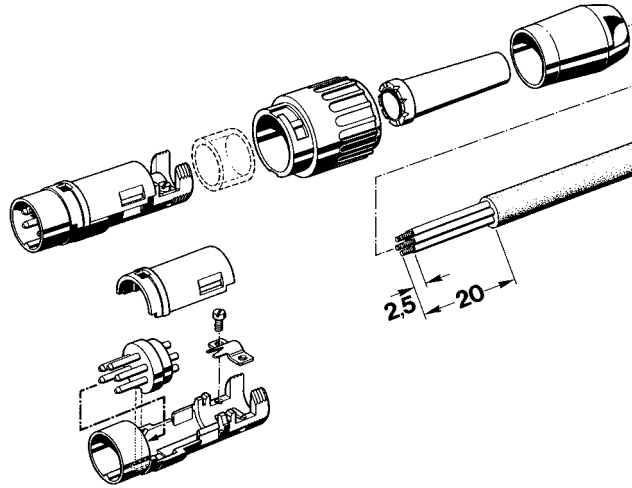

Male cable connector, max. cable outlet 6.5 mm or 8 mm

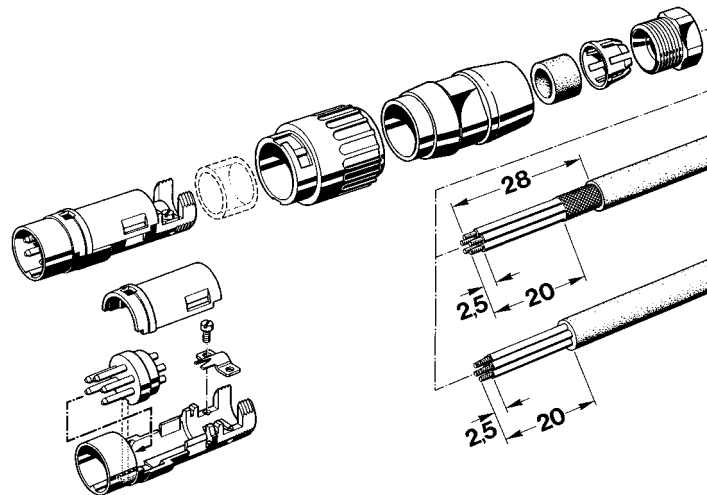

C 091 B

Female cable connector, bayonet locking inside

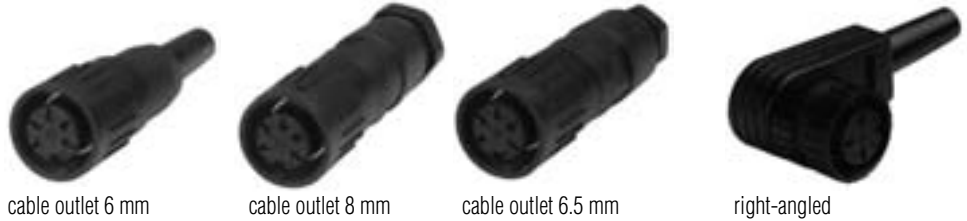

Description	Drawing	No. of cont.	Part Number solder termination		Part Number Crimp termination ¹⁾
			Contact plating silver	Contact plating gold ²⁾	
Female cable connector, max. cable outlet 6 mm, termination: solder or crimp, contact plating: silver or gold.		3 DIN	T 3275 501	T 3275 518 ⁴⁾	T 3275 551
		4 IEC	T 3325 501	T 3325 518	T 3325 551
		5	T 3375 501	T 3375 518 ⁴⁾	T 3375 551
		5 S DIN	T 3395 501 ⁴⁾	T 3395 518 ⁴⁾	T 3395 551 ⁴⁾
		6 DIN	T 3425 501	T 3425 518 ⁴⁾	T 3425 551
		7	T 3435 501	T 3435 518 ⁴⁾	T 3435 551
		7 DIN	T 3445 501 ⁴⁾	T 3445 518 ⁴⁾	T 3445 551 ⁴⁾
		8 DIN	T 3525 501 ⁴⁾	T 3525 518 ⁴⁾	T 3525 551 ⁴⁾
		12	T 3625 501 ⁴⁾	T 3625 518 ⁴⁾	—
		14	T 3645 501 ⁴⁾	T 3645 518 ⁴⁾	—
		Female cable connector, max. cable outlet 8 mm, termination: solder or crimp, contact plating: silver or gold.		3 DIN	T 3275 502
4 IEC	T 3325 502			T 3325 528 ⁴⁾	T 3325 552
5	T 3375 502			T 3375 528 ⁴⁾	T 3375 552
5 S DIN	T 3395 502 ⁴⁾			T 3395 528 ⁴⁾	T 3395 552 ⁴⁾
6 DIN	T 3425 502			T 3425 528 ⁴⁾	T 3425 552
7	T 3435 502			T 3435 528 ⁴⁾	T 3435 552
7 DIN	T 3445 502 ⁴⁾			T 3445 528 ⁴⁾	T 3445 552 ⁴⁾
8 DIN	T 3525 502 ⁴⁾			T 3525 528 ⁴⁾	T 3525 552 ⁴⁾
12	T 3625 502 ⁴⁾			T 3625 528 ⁴⁾	—
14	T 3645 502 ⁴⁾			T 3645 528 ⁴⁾	—
Female cable connector, max. cable outlet 6.5 mm, termination: solder or crimp, contact plating: silver or gold.				3 DIN	T 3275 504 ⁴⁾
		4 IEC	T 3325 504 ⁴⁾	T 3325 548 ⁴⁾	T 3325 554 ⁴⁾
		5	T 3375 504 ⁴⁾	T 3375 548 ⁴⁾	T 3375 554 ⁴⁾
		5 S DIN	T 3395 504 ⁴⁾	T 3395 548 ⁴⁾	T 3395 554 ⁴⁾
		6 DIN	T 3425 504 ⁴⁾	T 3425 548 ⁴⁾	T 3425 554 ⁴⁾
		7	T 3435 504 ⁴⁾	T 3435 548 ⁴⁾	T 3435 554 ⁴⁾
		7 DIN	T 3445 504 ⁴⁾	T 3445 548 ⁴⁾	T 3445 554 ⁴⁾
		8 DIN	T 3525 504 ⁴⁾	T 3525 548 ⁴⁾	T 3525 554 ⁴⁾
		12	T 3625 504 ⁴⁾	T 3625 548 ⁴⁾	—
		14	T 3645 504 ⁴⁾	T 3645 548 ⁴⁾	—
		Female cable connector, right-angled, max. cable outlet 6 mm, termination: solder or crimp, contact plating: silver or gold.		3 DIN	T 3275 005
4 IEC	T 3325 005			T 3325 058 ⁴⁾	T 3325 055 ⁴⁾
5	T 3375 005			T 3375 058 ⁴⁾	T 3375 055 ⁴⁾
5 S DIN	T 3395 005			T 3395 058 ⁴⁾	T 3395 055 ⁴⁾
6 DIN	T 3425 005			T 3425 058 ⁴⁾	T 3425 055 ⁴⁾
7	T 3435 005			T 3435 058 ⁴⁾	T 3435 055 ⁴⁾
7 DIN	T 3445 005 ⁴⁾			T 3445 058 ⁴⁾	T 3445 055 ⁴⁾
8 DIN	T 3525 005 ⁴⁾			T 3525 058 ⁴⁾	T 3525 055
12	T 3625 005			T 3625 058 ⁴⁾	—
14	T 3645 005			T 3645 058 ⁴⁾	—

¹⁾ Please order crimp contacts separately, see page 46 ²⁾ see remark page 23

⁴⁾ Available upon request. Min. order qty. 100 pcs/type.

C 091 B

Female cable connector,
bayonet locking inside,
assembling instructions

Female cable connector, max. cable outlet 6 mm

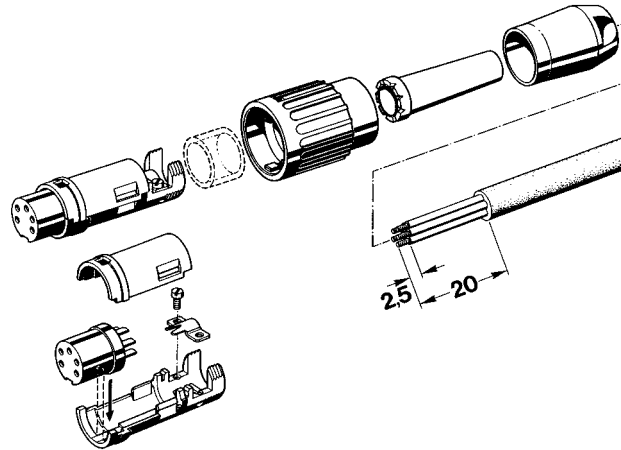

Female cable connector, max. cable outlet 6.5 mm or 8 mm

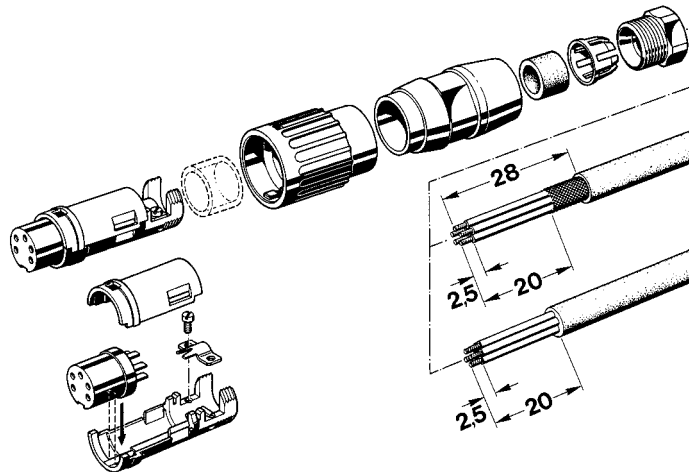

Female cable connector, right-angled

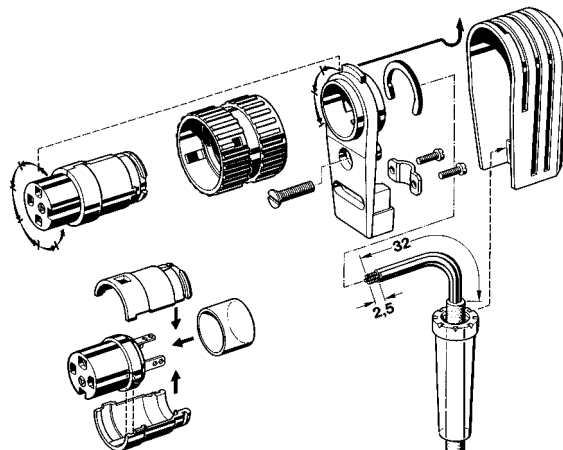

C 091 B

Female cable connector, bayonet locking outside



cable outlet 6 mm



cable outlet 8 mm



cable outlet 6.5 mm

Description	Drawing	No. of cont.	Part Number solder termination		Part Number Crimp termination ¹⁾
			Contact plating silver	Contact plating gold ²⁾	
Female cable connector, max. cable outlet 6 mm, termination: solder or crimp, contact plating: silver or gold.		3 DIN	T 3278 501	T 3278 518	T 3278 551
		4 IEC	T 3328 501	T 3328 518	T 3328 551
		5	T 3378 501	T 3378 518	T 3378 551
		5 S DIN	T 3398 501	T 3398 518	T 3398 551 ⁴⁾
		6 DIN	T 3428 501	T 3428 518	T 3428 551
		7	T 3438 501	T 3438 518 ⁴⁾	T 3438 551
		7 DIN	T 3448 501 ⁴⁾	T 3448 518 ⁴⁾	T 3448 551 ⁴⁾
		8 DIN	T 3528 501	T 3528 518 ⁴⁾	T 3528 551 ⁴⁾
		12	T 3628 501 ⁴⁾	T 3628 518 ⁴⁾	—
		14	T 3648 501 ⁴⁾	T 3648 518 ⁴⁾	—
		Female cable connector, max. cable outlet 8 mm, termination: solder or crimp, contact plating: silver or gold.		3 DIN	T 3278 502
4 IEC	T 3328 502			T 3328 528 ⁴⁾	T 3328 552
5	T 3378 502			T 3378 528 ⁴⁾	T 3378 552
5 S DIN	T 3398 502 ⁴⁾			T 3398 528 ⁴⁾	T 3398 552 ⁴⁾
6 DIN	T 3428 502			T 3428 528 ⁴⁾	T 3428 552
7	T 3438 502			T 3438 528 ⁴⁾	T 3438 552
7 DIN	T 3448 502 ⁴⁾			T 3448 528 ⁴⁾	T 3448 552 ⁴⁾
8 DIN	T 3528 502			T 3528 528 ⁴⁾	T 3528 552 ⁴⁾
12	T 3628 502 ⁴⁾			T 3628 528 ⁴⁾	—
14	T 3648 502 ⁴⁾			T 3648 528 ⁴⁾	—
Female cable connector, max. cable outlet 6.5 mm, termination: solder or crimp, contact plating: silver or gold.				3 DIN	T 3278 504 ⁴⁾
		4 IEC	T 3328 504 ⁴⁾	T 3328 548 ⁴⁾	T 3328 554 ⁴⁾
		5	T 3378 504 ⁴⁾	T 3378 548 ⁴⁾	T 3378 554 ⁴⁾
		5 S DIN	T 3398 504 ⁴⁾	T 3398 548 ⁴⁾	T 3398 554 ⁴⁾
		6 DIN	T 3428 504 ⁴⁾	T 3428 548 ⁴⁾	T 3428 554 ⁴⁾
		7	T 3438 504 ⁴⁾	T 3438 548 ⁴⁾	T 3438 554 ⁴⁾
		7 DIN	T 3448 504 ⁴⁾	T 3448 548 ⁴⁾	T 3448 554 ⁴⁾
		8 DIN	T 3528 504 ⁴⁾	T 3528 548 ⁴⁾	T 3528 554 ⁴⁾
		12	T 3628 504 ⁴⁾	T 3628 548 ⁴⁾	—
		14	T 3648 504 ⁴⁾	T 3648 548 ⁴⁾	—

¹⁾ Please order crimp contacts separately, see page 46 ²⁾ see remark page 23

⁴⁾ Available upon request. Min. order qty. 100 pcs/type.

C 091 B

Female cable connector,
bayonet locking outside,
assembling instructions

Female cable connector, max. cable outlet 6 mm

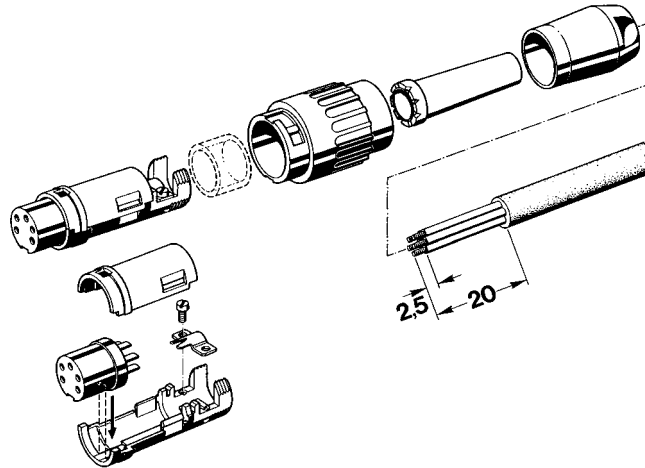

Female cable connector, max. cable outlet 6.5 mm or 8 mm

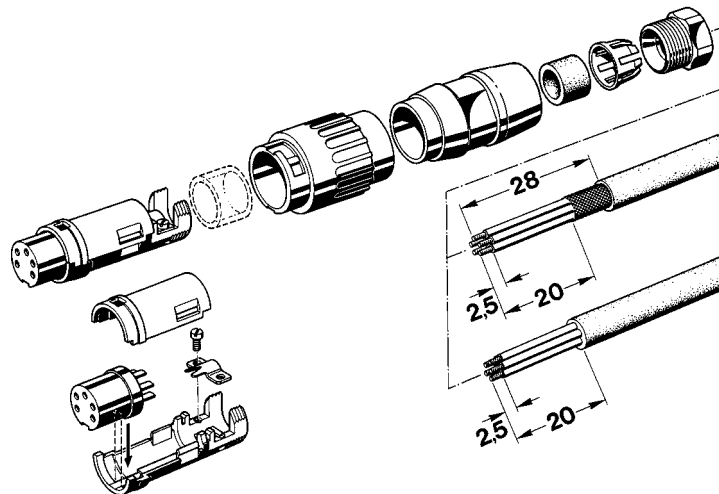

C 091 B

Male and female cable connector, full plastic, bayonet locking



Description	Drawing	No. of cont.	Part Number solder termination		Part Number Crimp termination ¹⁾
			Contact plating silver	Contact plating gold ²⁾	
Male cable connector, max. cable outlet 6 mm, termination: solder or crimp, contact plating: silver.		3 DIN	T 3274 991	–	T 3274 951 ⁴⁾
		4 IEC	T 3324 991	–	T 3324 951
		5 DIN	T 3374 991	–	T 3374 951
		6 DIN	T 3424 991	–	T 3424 951
		7	T 3434 991	–	T 3434 951 ⁴⁾
Female cable connector, max. cable outlet 6 mm, termination: solder or crimp, contact plating: silver.		3 DIN	T 3275 991	–	T 3275 951 ⁴⁾
		4 IEC	T 3325 991	–	T 3325 951 ⁴⁾
		5 DIN	T 3375 991	–	T 3375 951
		6 DIN	T 3425 991	–	T 3425 951 ⁴⁾
		7	T 3435 991	–	T 3435 951 ⁴⁾
Female cable connector, max. cable outlet 6 mm, termination: solder or crimp, contact plating: silver.		3 DIN	T 3278 991 ⁴⁾	–	T 3278 951 ⁴⁾
		4 IEC	T 3328 991	–	T 3328 951 ⁴⁾
		5 DIN	T 3378 991	–	T 3378 951 ⁴⁾
		6 DIN	T 3428 991	–	T 3428 951 ⁴⁾
		7	T 3438 991 ⁴⁾	–	T 3438 951 ⁴⁾

¹⁾ Please order crimp contacts separately, see page 46 ²⁾ see remark page 23

⁴⁾ Available upon request. Min. order qty.100 pcs/type.

C 091 B

Female receptacle, bayonet locking



Ring nut



Bayonet outside



Bayonet inside

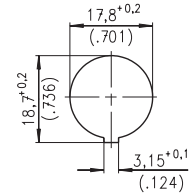

Panel cutout

Description	Drawing	No. of cont.	Part Number solder termination		Part Number Crimp termination ¹⁾		
			Contact plating silver	Contact plating gold ²⁾			
Female receptacle, bayonet locking, outside, shell: full plastic, front mounting, termination: solder or crimp, panel mounting with ring nut ³⁾ , contact plating: silver or gold. solder area: tin plated		3 DIN	T 3277 000	T 3277 018 ⁴⁾	T 3277 050		
		4 IEC	T 3327 000	T 3327 018 ⁴⁾	T 3327 050		
		5	T 3377 000	T 3377 018 ⁴⁾	T 3377 050		
		5 S DIN	–	–	–		
		6 DIN	T 3427 000	T 3427 018 ⁴⁾	T 3427 050		
		7	T 3437 000	T 3437 018 ⁴⁾	T 3437 050		
		7 DIN	–	–	–		
		8 DIN	–	–	–		
		12	–	–	–		
		14	–	–	–		
		Female receptacle, bayonet locking, outside, shell: full plastic, front mounting, termination: solder or crimp, snap-in-mounting, contact plating: silver or gold. solder area: tin plated	<p>max. panel thickness 1,5±0,25</p>	3 DIN	T 3277 500	T 3277 518 ⁴⁾	T 3277 550
				4 IEC	T 3327 500	T 3327 518 ⁴⁾	T 3327 550
				5	T 3377 500	T 3377 518 ⁴⁾	T 3377 550
				5 S DIN	T 3397 500 ⁴⁾	T 3397 518 ⁴⁾	T 3397 550 ⁴⁾
6 DIN	T 3427 500			T 3427 518 ⁴⁾	T 3427 550		
7	T 3437 500			T 3437 518 ⁴⁾	T 3437 550		
7 DIN	T 3447 500 ⁴⁾			T 3447 518 ⁴⁾	T 3447 550 ⁴⁾		
8 DIN	T 3527 500			T 3527 518 ⁴⁾	–		
12	T 3627 500			T 3627 518 ⁴⁾	–		
14	T 3647 500			T 3647 518 ⁴⁾	–		
Female receptacle, bayonet locking, inside, shell: full plastic, front mounting, termination: solder or crimp, snap-in-mounting, contact plating: silver or gold. solder area: tin plated	<p>max. panel thickness 1,5±0,25</p>			3 DIN	T 3271 500	T 3271 518 ⁴⁾	T 3271 550
				4 IEC	T 3321 500	T 3321 518 ⁴⁾	T 3321 550
				5	T 3371 500	T 3371 518 ⁴⁾	T 3371 550
				5 S DIN	T 3391 500 ⁴⁾	T 3391 518 ⁴⁾	T 3391 550 ⁴⁾
		6 DIN	T 3421 500	T 3421 518 ⁴⁾	T 3421 550		
		7	T 3431 500	T 3431 518 ⁴⁾	T 3431 550		
		7 DIN	T 3441 500 ⁴⁾	T 3441 518 ⁴⁾	T 3441 550 ⁴⁾		
		8 DIN	T 3521 500	T 3521 518 ⁴⁾	T 3521 550 ⁴⁾		
		12	T 3621 500	T 3621 518 ⁴⁾	–		
		14	T 3641 500	T 3641 518 ⁴⁾	–		
		Female receptacle, bayonet locking, outside, shell: metal, rear mounting, termination: solder or crimp, panel mounting with ring nut ³⁾ , contact plating: silver. solder area: tin plated	<p>panel cutout see page 17</p>	3 DIN	T 3277 100	–	T 3277 150
				4 IEC	T 3327 100	–	T 3327 150 ⁴⁾
				5	T 3377 100	–	T 3377 150 ⁴⁾
				5 S DIN	T 3397 100	–	T 3397 150
6 DIN	T 3427 100			–	T 3427 150 ⁴⁾		
7	T 3437 100 ⁴⁾			–	T 3437 150 ⁴⁾		
7 DIN	T 3447 100			–	T 3447 150		
8 DIN	T 3527 100			–	T 3527 150		
12	T 3627 100 ⁴⁾			–	–		
14	T 3647 100 ⁴⁾			–	–		

¹⁾ Please order crimp contacts separately, see page 46 ²⁾ see remark page 23 ³⁾ Panel mounting with hex nut upon request

⁴⁾ Available upon request. Min. order qty.100 pcs/type.

C 091 B

Female receptacle,
bayonet locking
outside
right-angled



full plastic



metal

Description	Drawing	No. of cont.	Part Number solder termination contact plating silver		Part Number Crimp termination ¹⁾
			housing grey	housing black	
Female receptacle, bayonet locking, outside, right-angled, shell: full plastic, contact plating: silver.	<p>A: 3pol. = 14 (.551) 5pol.+7pol.=15,9 (.650) 6pol. = 18 (.746)</p>	3 DIN	T 3277 200	T 3277 600	-
		4 IEC	-	-	-
		5	T 3377 200	T 3377 600	-
		5 S DIN	T 3397 200	T 3397 600	-
		6 DIN	T 3427 200	T 3427 600	-
		7	-	-	-
		7 DIN	-	-	-
		8 DIN	-	-	-
		12	-	-	-
		14	-	-	-

PCB-layout

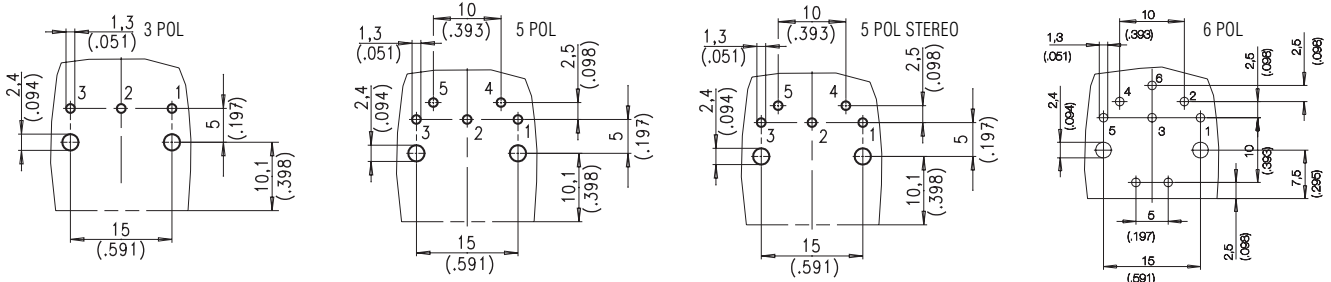

Description	Drawing	No. of cont.	Part Number solder termination contact plating silver		Part Number Crimp termination ¹⁾
			housing grey	housing black	
Female receptacle, bayonet locking, outside, right-angled, shell: metal, contact plating: silver.	<p>A: 3pol. = 14 (.551) 5pol.+7pol.=15,9 (.650) 8pol. = 18 (.748)</p>	3 DIN	T 3277 900	-	-
		4 IEC	-	-	-
		5	-	-	-
		5 S DIN	T 3397 900	-	-
		6 DIN	-	-	-
		7	-	-	-
		7 DIN	T 3447 900	-	-
		8 DIN	T 3527 900	-	-
		12	-	-	-
		14	-	-	-

PCB-layout

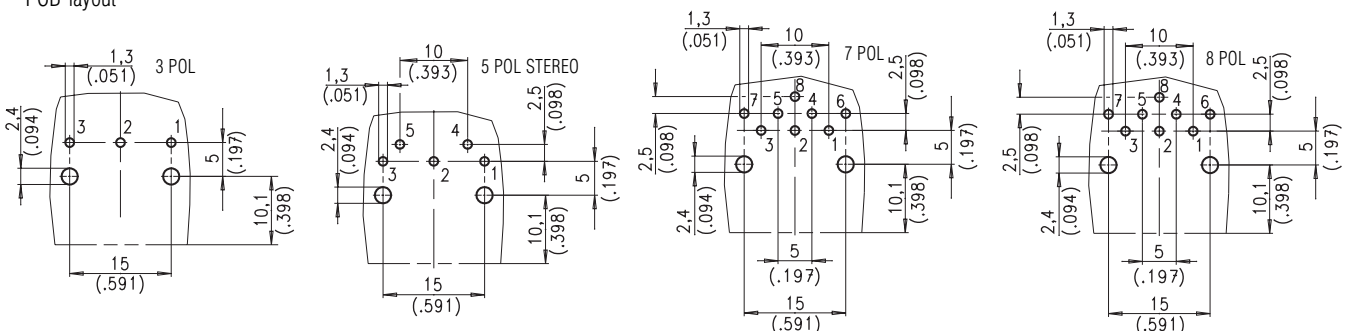

C 091 B

Male receptacle,
bayonet locking, outside

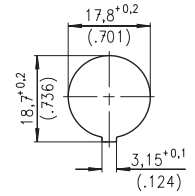

Montageausschnitt

Description	Drawing	No. of cont.	Part Number solder termination		Part Number Crimp termination ¹⁾
			Contact plating silver	Contact plating gold ²⁾	
Male receptacle, bayonet locking, outside, front mounting, shell: full plastic, termination: solder or crimp, snap-in-mounting, contact plating: silver or gold.	<p>max. panel thickness 1,5^{+0,25}</p>	3 DIN	T 3276 500	T 3276 518 ⁴⁾	T 3276 550
		4 IEC	T 3326 500	T 3326 518 ⁴⁾	T 3326 550
		5	T 3376 500	T 3376 518 ⁴⁾	T 3376 550
		5 S DIN	T 3396 500 ⁴⁾	T 3396 518 ⁴⁾	T 3396 550 ⁴⁾
		6 DIN	T 3426 500	T 3426 518 ⁴⁾	T 3426 550
		7	T 3436 500	T 3436 518 ⁴⁾	T 3436 550
		7 DIN	T 3446 500 ⁴⁾	T 3446 518 ⁴⁾	T 3446 550 ⁴⁾
		8 DIN	T 3526 500 ⁴⁾	T 3526 518 ⁴⁾	T 3526 550 ⁴⁾
		12	T 3626 500 ⁴⁾	T 3626 518 ⁴⁾	—
		14	T 3646 500 ⁴⁾	T 3646 518 ⁴⁾	—

¹⁾ Please order crimp contacts separately, see page 46 ²⁾ see remark page 23 ³⁾ Panel mounting with hex nut upon request

⁴⁾ Available upon request. Min. order qty. 100 pcs/type.

C 091 D

Main Features

- Precision metal construction.
- Ingress Protection class IP 67.
- Threaded coupling acc. to IEC 130-9.
- Number of contacts are 3 to 8, 12 and 14.
- Internal metal strain relief.
- Complete EMI shielding in the fully mated and locked position (EMI security).
- Male and female cable connectors: solder in 3 to 8, 12, 14 positions; crimp in 3 to 8 positions; cable outlet in PG 7 for diameter of 6 mm; cable outlet in PG 9 for diameter of 8 mm ; straight cable entry; metal coupling nickel plated
- Male and female receptacles for panel mount: front or rear mounting, solder in 3 to 8, 12, 14 positions; crimp in 3 to 8 positions; PCB mounting, vertical, using dip solder termination with multiple tail lengths.
- The connectors are registered under File # E 63 093 UL.



UNDERWRITERS LABORATORIES INC.

C 091 D

Characteristics

General Characteristics	Standard	Characteristics									
		3	4	5	5 Stereo	6	7	7	8	12	14
Number of contacts		3	4	5	5 Stereo	6	7	7	8	12	14
View on termination side of contact insert											
Contact arrangement acc. to DIN		41 524	–	–	41 524	41 322	–	45 329	45 326	–	–
Contact arrangement acc. to IEC		130-9	–	–	130-9	130-9	–	130-9	130-9	–	–
Electrical Characteristics											
Rated voltage	IEC 60664-1	300 V ≈			100V ≈	300 V ≈			150 V ≈		
Rated impulse withstand voltage	IEC 60664-1	1500 V			1200 V	1500 V			1200 V		
Pollution degree	IEC 60664-1	1									
Installation category	IEC 60664-1	I									
Insulation group	IEC 60664-1	3									
Test voltage	IEC 60664-1	980 V ~			670 V ~	980 V ~			670 V ~		
Current rating	IEC 60512-3 Test 5 b	5 A / + 40 °C / + 104 °F								3 A / + 40 °C / + 104 °F	
Insulation resistance	IEC 60512-2 Test 3 a	> 10 ¹² Ω									
Contact resistance	IEC 60512-2 Test 2 a	< 5 m Ω									
Climatical Characteristics											
Climatic category	IEC 60668-1	40 / 85 / 56									
Temperature range	IEC 60668-1	- 40 °C ... + 85 °C / - 40 °F ... + 185 °F									
Mechanical Characteristics											
IP-degree	IEC 60529	IP 67, cable diameter PG 7: .137 - .236, PG 9: .236 - .314									
Insertion and withdrawal forces	IEC 60512-7 Test 13 b	25 N 90.oz	30 N 110.oz	35 N 125.oz	50 N 180.oz	55 N 200.oz	60 N 220.oz	60 N 220.oz	50 N 180.oz		
Mechanical operation	IEC 60512-5 Test 9 a	Silver ≥ 500 mating cycles Gold ≥ 1000 mating cycles									
Materials											
Housing material		die cast, nickel plated									
Dielectric material		thermoplastic									
Sealing material		neoprene									
Contact plating		silver plated / gold plated *									
Further Characteristics											
Termination technique		solder, crimp								solder	
Wire gauge		solder ≤ 0,5 mm ² (20-26 AWG), crimp 0,14 – 1,0 mm ² (26-18 AWG)								≤ 0,25 mm/24 AWG	
Flammability		UL 94 V0									
Locking system	IEC 130-9	metal screw coupling									

Characteristics

Do not connect or disconnect under load. Metal housing parts shall be securely incorporated to protected ground.

* Remark for gold plated contacts

To avoid brittle intermetallic connections gold-plated soldering terminals must be pre-tinned before soldering.

C 091 D

Male cable connector

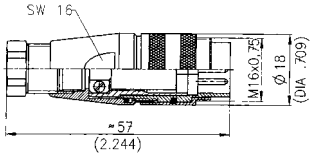
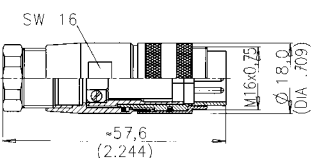

Description	Drawing	No. of cont.	Part Number solder termination		Part Number Crimp termination ¹⁾
			Contact plating silver	Contact plating gold ²⁾	
Male cable connector. Max. cable outlet 6 mm, termination: solder or crimp, contact plating: silver or gold.	 PG 7	3 DIN	C091 31H003 100 2	–	C091 11H003 000 2
		4 IEC	C091 31H004 100 2	–	C091 11H004 000 2
		5 DIN	C091 31H005 100 2	–	C091 11H005 000 2
		5S DIN	C091 31H105 100 2	–	C091 11H105 000 2
		6 DIN	C091 31H006 100 2	–	C091 11H006 000 2
		7	C091 31H007 100 2	–	C091 11H007 000 2
		7 DIN	C091 31H107 100 2	–	C091 11H107 000 2
		8 DIN	C091 31H008 100 2	–	C091 11H008 000 2
		12	C091 31H012 100 2	C091 31H012 200 2	–
		14	C091 31H014 100 2	C091 31H014 200 2	–
Male cable connector. Max. cable outlet 8 mm, termination: solder or crimp, contact plating: silver or gold.	 PG 9	3 DIN	C091 31H003 101 2	–	C091 11H003 001 2
		4 IEC	C091 31H004 101 2	–	C091 11H004 001 2
		5 DIN	C091 31H005 101 2	–	C091 11H005 001 2
		5S DIN	C091 31H105 101 2	–	C091 11H105 001 2
		6 DIN	C091 31H006 101 2	–	C091 11H006 001 2
		7	C091 31H007 101 2	–	C091 11H007 001 2
		7 DIN	C091 31H107 101 2	–	C091 11H107 001 2
		8 DIN	C091 31H008 101 2	–	C091 11H008 001 2
		12	–	C091 31H012 201 2	–
		14	–	C091 31H014 201 2	–

¹⁾ Please order crimp contacts separately, see page 46 ²⁾ see remark page 39

Assembling instruction

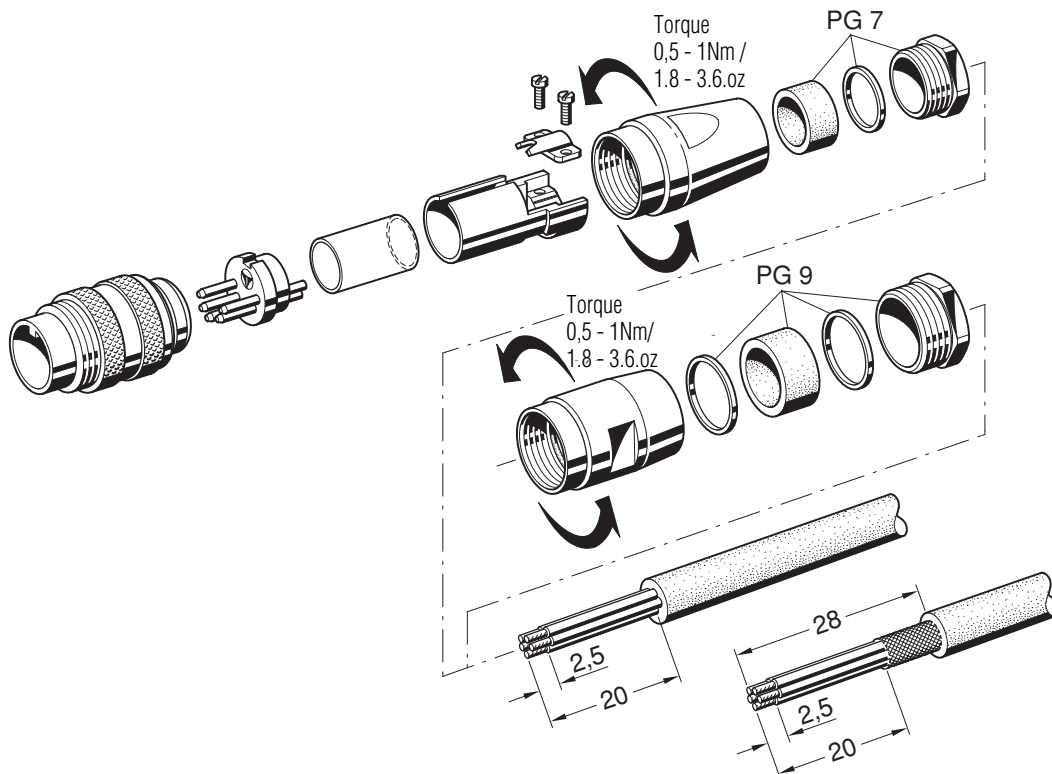

C 091 D

Female cable connector

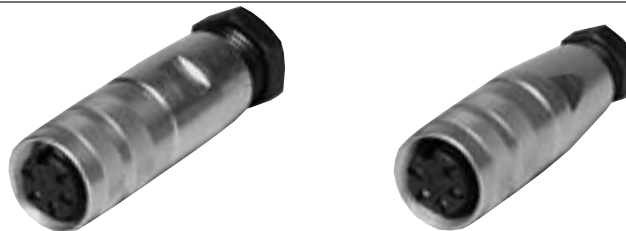

Description	Drawing	No. of cont.	Part Number solder termination		Part Number Crimp termination ¹⁾
			Contact plating silver	Contact plating gold ²⁾	
Female cable connector. Max. cable outlet 6 mm, termination: solder or crimp, contact plating: silver or gold.	<p>PG 7</p>	3 DIN	C091 31D003 100 2	–	C091 11D003 000 2
		4 IEC	C091 31D004 100 2	–	C091 11D004 000 2
		5 DIN	C091 31D005 100 2	–	C091 11D005 000 2
		5S DIN	C091 31D105 100 2	–	C091 11D105 000 2
		6 DIN	C091 31D006 100 2	–	C091 11D006 000 2
		7	C091 31D007 100 2	–	C091 11D007 000 2
		7 DIN	C091 31D107 100 2	–	C091 11D107 000 2
		8 DIN	C091 31D008 100 2	–	C091 11D008 000 2
		12	C091 31D012 100 2	C091 31D012 200 2	–
		14	C091 31D014 100 2	C091 31D014 200 2	–
Female cable connector. Max. cable outlet 8 mm, termination: solder or crimp, contact plating: silver or gold.	<p>PG 9</p>	3 DIN	C091 31D003 101 2	–	C091 11D003 001 2
		4 IEC	C091 31D004 101 2	–	C091 11D004 001 2
		5 DIN	C091 31D005 101 2	–	C091 11D005 001 2
		5S DIN	C091 31D105 101 2	–	C091 11D105 001 2
		6 DIN	C091 31D006 101 2	–	C091 11D006 001 2
		7	C091 31D007 101 2	–	C091 11D007 001 2
		7 DIN	C091 31D107 101 2	–	C091 11D107 001 2
		8 DIN	C091 31D008 101 2	–	C091 11D008 001 2
		12	–	C091 31D012 201 2	–
		14	–	C091 31D014 201 2	–

¹⁾ Please order crimp contacts separately, see page 46 ²⁾ see remark page 39

Assembling instruction

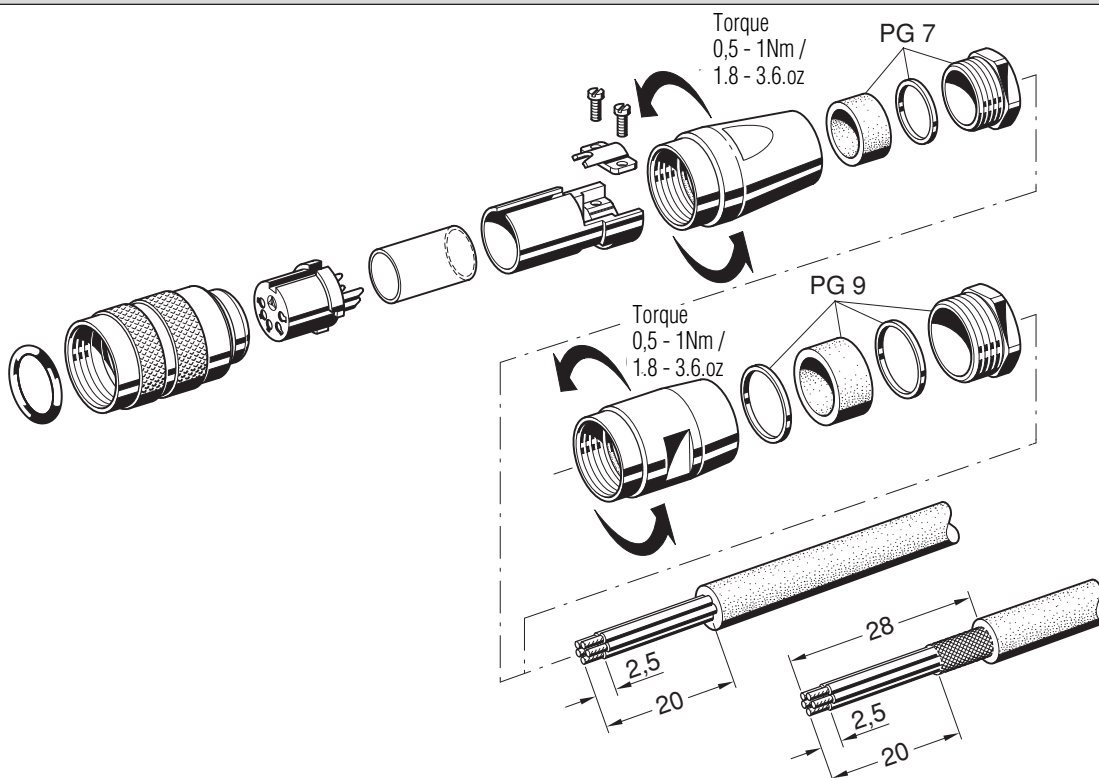

C 091 D

Female receptacle for front mounting

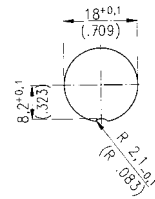
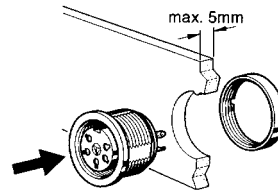

Assembling instruction

Panel Cutout

Description	Drawing	No. of cont.	Part Number solder termination		Part Number Crimp termination ¹⁾
			Contact plating silver	Contact plating gold ²⁾	
Female receptacle, termination: solder or crimp, contact plating: silver or gold, panel mounting with ring nut, sealing with O-Ring, solder area: tin plated.		3 DIN	C091 31N003 100 2	–	C091 11N003 000 2
		4 IEC	C091 31N004 100 2	–	C091 11N004 000 2
		5 DIN	C091 31N005 100 2	–	C091 11N005 000 2
		5S DIN	C091 31N105 100 2	–	C091 11N105 000 2
		6 DIN	C091 31N006 100 2	–	C091 11N006 000 2
		7	C091 31N007 100 2	–	C091 11N007 000 2
		7 DIN	C091 31N107 100 2 ⁴⁾	–	C091 11N107 000 2
		8 DIN	C091 31N008 100 2	–	C091 11N008 000 2
		12	–	C091 31N012 200 2 ⁴⁾	–
		14	–	C091 31N014 200 2 ⁴⁾	–
Female receptacle, termination: straight dip solder, contact plating: silver or gold, pin length 15 mm (12 + 14 contacts: 18 mm) from flange, panel mounting with ring nut, sealing with O-Ring, solder area: tin plated.		3 DIN	C091 61N003 110 2	–	–
		4 IEC	C091 61N004 110 2	–	–
		5 DIN	C091 61N005 110 2	–	–
		5S DIN	C091 61N105 110 2	–	–
		6 DIN	C091 61N006 110 2	–	–
		7	C091 61N007 110 2	–	–
		7 DIN	C091 61N107 110 2	–	–
		8 DIN	C091 61N008 110 2	–	–
		12	–	C091 61N012 210 2	–
		14	–	C091 61N014 210 2	–
Female receptacle, termination: straight dip solder, contact plating: silver, panel mounting with ring nut, sealing with O-Ring, solder area: tin plated.		3 DIN	C091 61N003 120 2	–	–
		4 IEC	C091 61N004 120 2	–	–
		5 DIN	C091 61N005 120 2	–	–
		5S DIN	C091 61N105 120 2	–	–
		6 DIN	C091 61N006 120 2	–	–
		7	C091 61N007 120 2	–	–
		7 DIN	C091 61N107 120 2	–	–
		8 DIN	C091 61N008 120 2	–	–
		12	–	–	–
		14	–	–	–
Female receptacle, termination: straight dip solder, contact plating: silver, panel mounting with ring nut, sealing with O-Ring, solder area: tin plated.		3 DIN	C091 61N003 130 2	–	–
		4 IEC	C091 61N004 130 2	–	–
		5 DIN	C091 61N005 130 2	–	–
		5S DIN	C091 61N105 130 2	–	–
		6 DIN	C091 61N006 130 2	–	–
		7	C091 61N007 130 2	–	–
		7 DIN	C091 61N107 130 2	–	–
		8 DIN	C091 61N008 130 2	–	–
		12	–	–	–
		14	–	–	–

¹⁾ Please order crimp contacts separately, see page 46 ²⁾ see remark page 39

⁴⁾ Available upon request. Min. order qty.100 pcs/type.

C 091 D

Female receptacle for rear mounting

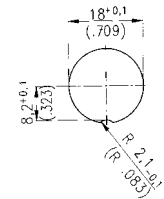
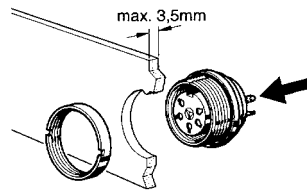

Assembling instruction

Panel Cutout

Description	Drawing	No. of cont.	Part Number solder termination		Part Number Crimp termination ¹⁾		
			Contact plating silver	Contact plating gold ²⁾			
Female receptacle, termination: solder or crimp, contact plating: silver or gold, panel mounting with ring nut, sealing with O-Ring, solder area: tin plated.		3 DIN	C091 31G003 100 2	–	C091 11G003 000 2 ⁴⁾		
		4 IEC	C091 31G004 100 2	–	C091 11G004 000 2		
		5 DIN	C091 31G005 100 2	–	C091 11G005 000 2 ⁴⁾		
		5S DIN	C091 31G105 100 2	–	C091 11G105 000 2		
		6 DIN	C091 31G006 100 2	–	C091 11G006 000 2 ⁴⁾		
		7	C091 31G007 100 2	–	C091 11G007 000 2 ⁴⁾		
		7 DIN	C091 31G107 100 2	–	C091 11G107 000 2		
		8 DIN	C091 31G008 100 2	–	C091 11G008 000 2		
		12	C091 31G012 100 2	C091 31G012 200 2	–		
		14	C091 31G014 100 2	C091 31G014 200 2	–		
		Female receptacle, termination: straight dip solder, contact plating: silver or gold, pin length 10.5 mm (12 + 14 contacts: 13.5 mm) from flange, panel mounting with ring nut, sealing with O-Ring, solder area: tin plated.		3 DIN	C091 61G003 110 2	–	–
				4 IEC	C091 61G004 110 2	–	–
				5 DIN	C091 61G005 110 2	–	–
				5S DIN	C091 61G105 110 2	–	–
6 DIN	C091 61G006 110 2			–	–		
7	C091 61G007 110 2			–	–		
7 DIN	C091 61G107 110 2			–	–		
8 DIN	C091 61G008 110 2			–	–		
12	C091 61G012 110 2			C091 61G012 210 2	–		
14	C091 61G014 110 2			C091 61G014 210 2	–		
Female receptacle, termination: straight dip solder, contact plating: silver, panel mounting with ring nut, sealing with O-Ring, solder area: tin plated.				3 DIN	C091 61G003 120 2	–	–
				4 IEC	C091 61G004 120 2	–	–
				5 DIN	C091 61G005 120 2	–	–
				5S DIN	C091 61G105 120 2	–	–
		6 DIN	C091 61G006 120 2	–	–		
		7	C091 61G007 120 2	–	–		
		7 DIN	C091 61G107 120 2	–	–		
		8 DIN	C091 61G008 120 2	–	–		
		12	–	–	–		
		14	–	–	–		
		Female receptacle, termination: straight dip solder, contact plating: silver, panel mounting with ring nut, sealing with O-Ring, solder area: tin plated.		3 DIN	C091 61G003 130 2	–	–
				4 IEC	C091 61G004 130 2	–	–
				5 DIN	C091 61G005 130 2	–	–
				5S DIN	C091 61G105 130 2	–	–
6 DIN	C091 61G006 130 2			–	–		
7	C091 61G007 130 2			–	–		
7 DIN	C091 61G107 130 2			–	–		
8 DIN	C091 61G008 130 2			–	–		
12	–			–	–		
14	–			–	–		

¹⁾ Please order crimp contacts separately, see page 46 ²⁾ see remark page 39

⁴⁾ Available upon request. Min. order qty. 100 pcs/type.

C 091 D

Female receptacle for flange mounting

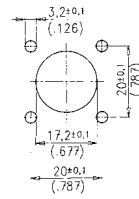

Panel Cutout

Description	Drawing	No. of cont.	Part Number solder termination		Part Number Crimp termination ¹⁾
			Contact plating silver	Contact plating gold ²⁾	
Female receptacle, square flange, termination: solder, contact plating: silver or gold, with sealing gasket.		3 DIN	C091 31T003 100 2	–	–
		4 IEC	C091 31T004 100 2	–	–
		5 DIN	C091 31T005 100 2	–	–
		5S DIN	C091 31T105 100 2	–	–
		6 DIN	C091 31T006 100 2	–	–
		7	C091 31T007 100 2	–	–
		7 DIN	C091 31T107 100 2 ⁴⁾	–	–
		8 DIN	C091 31T008 100 2	–	–
		12	–	C091 31T012 200 2	–
		14	–	C091 31T014 200 2	–

C 091 D

Male receptacle for front mounting

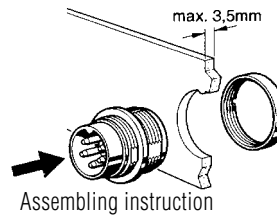

Assembling instruction

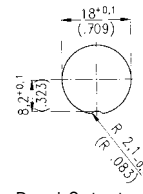

Panel Cutout

Description	Drawing	No. of cont.	Part Number solder termination		Part Number Crimp termination ¹⁾
			Contact plating silver	Contact plating gold ²⁾	
Male receptacle, termination: solder or crimp, contact plating: silver or gold, panel mounting with ring nut, sealing with O-Ring.		3 DIN	C091 31W003 100 2	–	C091 11W003 000 2
		4 IEC	C091 31W004 100 2	–	C091 11W004 000 2
		5 DIN	C091 31W005 100 2	–	C091 11W005 000 2
		5S DIN	C091 31W105 100 2	–	C091 11W105 000 2
		6 DIN	C091 31W006 100 2	–	C091 11W006 000 2
		7	C091 31W007 100 2	–	C091 11W007 000 2
		7 DIN	C091 31W107 100 2	–	C091 11W107 000 2
		8 DIN	C091 31W008 100 2	–	C091 11W008 000 2
		12	–	C091 31W012 200 2	–
		14	–	C091 31W014 200 2	–

¹⁾ Please order crimp contacts separately, see page 46 ²⁾ see remark page 39

⁴⁾ Available upon request. Min. order qty.100 pcs/type.

C 091 D

Male receptacle for rear mounting

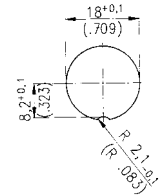
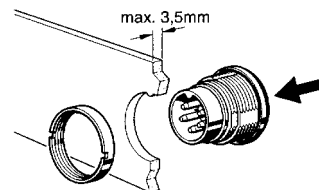

Assembling instruction

Panel Cutout

Description	Drawing	No. of cont.	Part Number solder termination		Part Number Crimp termination ¹⁾
			Contact plating silver	Contact plating gold ²⁾	
Male receptacle, termination: solder or crimp, contact plating: silver or gold, panel mounting with ring nut, sealing with O-Ring.		3 DIN	C091 31C003 100 2	–	C091 11C003 000 2 ⁴⁾
		4 IEC	C091 31C004 100 2	–	C091 11C004 000 2 ⁴⁾
		5 DIN	C091 31C005 100 2	–	C091 11C005 000 2 ⁴⁾
		5S DIN	C091 31C105 100 2	–	C091 11C105 000 2 ⁴⁾
		6 DIN	C091 31C006 100 2	–	C091 11C006 000 2 ⁴⁾
		7	C091 31C007 100 2	–	C091 11C007 000 2
		7 DIN	C091 31C107 100 2	–	C091 11C107 000 2 ⁴⁾
		8 DIN	C091 31C008 100 2	–	C091 11C008 000 2
		12	–	C091 31C012 200 2	–
		14	–	C091 31C014 200 2	–

C 091 D

Male receptacle for flange mounting

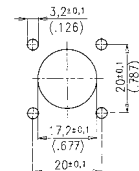

Panel Cutout

Description	Drawing	No. of cont.	Part Number solder termination		Part Number Crimp termination ¹⁾
			Contact plating silver	Contact plating gold ²⁾	
Male receptacle, square flange, termination: solder, contact plating: silver or gold, with sealing gasket.		3 DIN	C091 31S003 100 2	–	–
		4 IEC	C091 31S004 100 2	–	–
		5 DIN	C091 31S005 100 2	–	–
		5S DIN	C091 31S105 100 2	–	–
		6 DIN	C091 31S006 100 2	–	–
		7	C091 31S007 100 2	–	–
		7 DIN	C091 31S107 100 2	–	–
		8 DIN	C091 31S008 100 2	–	–
		12	–	C091 31S012 200 2	–
		14	–	C091 31S014 200 2	–

¹⁾ Please order crimp contacts separately, see page 46 ²⁾ see remark page 39

⁴⁾ Available upon request. Min. order qty.100 pcs/type.

C 091

Crimp contacts





Pin contact



Socket contact

Typ of Contact	Contact Ø	Wire Gauge	max. Insul. Ø	Supplied as	Pcs.	Part Number	
						silver	gold
Pin contact	1.5 mm	0.14-0.5 mm ² AWG 26-20	2.0 ^{+0.2} mm	single contact	100	VN01 015 0005 (1)	VN01 015 0005 (2)
				contacts on reel	200	ZN01 015 0005 (1)	ZN01 015 0005 (2)
					2000	HN01 015 0005 (1)	HN01 015 0005 (2)
		0.5-1.0 mm ² AWG 20-18	2.0 ^{+0.2} mm	single contact	100	VN01 015 0039 (1)	VN01 015 0039 (2)
				contacts on reel	200	ZN01 015 0039 (1)	ZN01 015 0039 (2)
					2000	HN01 015 0039 (1)	HN01 015 0039 (2)
Socket contact	1.5 mm	0.14-0.5 mm ² AWG 26-20	2.0 ^{+0.2} mm	single contact	100	VN02 015 0005 (1)	VN02 015 0005 (2)
				contacts on reel	200	ZN02 015 0005 (1)	ZN02 015 0005 (2)
					2000	HN02 015 0005 (1)	HN02 015 0005 (2)
		0.5-1.0 mm ² AWG 20-18	2.0 ^{+0.2} mm	single contact	100	VN02 015 0039 (1)	VN02 015 0039 (2)
				contacts on reel	200	ZN02 015 0039 (1)	ZN02 015 0039 (2)
					2000	HN02 015 0039 (1)	HN02 015 0039 (2)





For more information upon crimping tools please contact factory or order our catalogue.

Minimum retention forces according to IEC 352-2							
Wires				Wires			
Wire size		Minimum retention force	Crimp height (average values)	Wire size		Minimum retention force	Crimp height (average values)
mm ²		N	 h max mm	mm ²	AWG	N	 h max mm
0.14 - 0.5 AWG 26-20	0.14	24	0.9 - 1.01	0.14 - 0.5	26	24	0.9 - 1.0
	0.25	42	0.92 - 1.09		24	39	0.92 - 1.02
	0.5	73	0.95 - 1.11 1.3 - 1.39		22	53	0.93 - 1.03
0.5 - 1.5 AWG 20-16	0.75	101	1.34 - 1.4	20	84	0.95 - 1.10 1.24 - 1.34	
	1	135	1.36 - 1.44	0.5 - 1.5	18	131	1.32 - 1.42

These min. values are based on the copper wire tensile strength with $\delta_B \approx 230 \text{ N/mm}^2$.

C 091

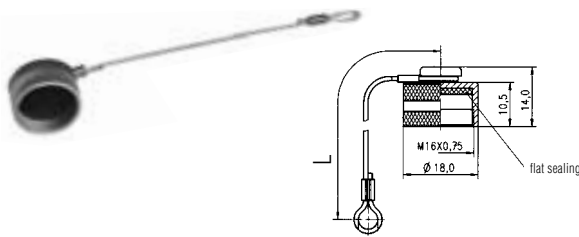
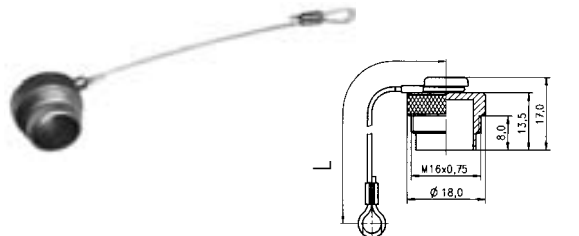
Accessories

Description	for Series	Drawing	Part Number		
Spanner wrench for receptacles with ring nut.	C 091 A C 091 B C 091 D		N 45 091-000 1		
Spanner wrench for male and female cable connectors.	C 091 A C 091 B C 091 D		FH 0300-091		
Protective cover for male cable connectors and male receptacles.	C 091 A C 091 D		for male cable connectors C 091 00U000 100 2 L = 100 for male receptacles C 091 00U000 110 2 L = 80		
Protective cover for female cable connectors and female receptacles.	C 091 A C 091 D		for female cable connectors C 091 00V000 100 2 L = 100 for female receptacles C 091 00V000 110 2 L = 80		
Safety washer for male and female receptacles. Packaging unit: 25 pieces	C 091 A C 091 B		VN 05 180 000 1 (1)		
Colored back-shells	C 091 A C 091 B		Colour	Pieces	Part Number
			blue	10 100	T 2993 510 9X T 2993 510 9C
			red	10 100	T 2993 511 9X T 2993 511 9C
			yellow	10 100	T 2993 512 9X T 2993 512 9C
			green	10 100	T 2993 513 9X T 2993 513 9C

Summary of Part Numbers

Part Number	Page	Part Number	Page	Part Number	Page	Part Number	Page	Part Number	Page	Part Number	Page
C 091 00U000 100 2	47	C091 31C007 100 2	45	C091 31S003 100 2	45	C091 61N007 130 2	42	T 3260 018	10	T 3275 554	28
C 091 00U000 110 2	47	C091 31C008 100 2	45	C091 31S004 100 2	45	C091 61N008 110 2	42	T 3260 028	10	T 3275 951	32
C 091 00V000 100 2	47	C091 31C012 200 2	45	C091 31S005 100 2	45	C091 61N008 120 2	42	T 3260 048	10	T 3275 991	32
C 091 00V000 110 2	47	C091 31C014 200 2	45	C091 31S006 100 2	45	C091 61N008 130 2	42	T 3260 055	11	T 3276 500	35
C091 11C003 000 2	45	C091 31C105 100 2	45	C091 31S007 100 2	45	C091 61N012 210 2	42	T 3260 058	11	T 3276 518	35
C091 11C004 000 2	45	C091 31C107 100 2	45	C091 31S008 100 2	45	C091 61N014 210 2	42	T 3260 551	10	T 3276 550	35
C091 11C005 000 2	45	C091 31D003 100 2	41	C091 31S012 200 2	45	C091 61N105 110 2	42	T 3260 552	10	T 3277 000	33
C091 11C006 000 2	45	C091 31D003 101 2	41	C091 31S014 200 2	45	C091 61N105 120 2	42	T 3260 554	10	T 3277 018	33
C091 11C007 000 2	45	C091 31D004 100 2	41	C091 31S105 100 2	45	C091 61N105 130 2	42	T 3261 001	12	T 3277 050	33
C091 11C008 000 2	45	C091 31D004 101 2	41	C091 31S107 100 2	45	C091 61N107 110 2	42	T 3261 002	12	T 3277 100	33
C091 11C105 000 2	45	C091 31D005 100 2	41	C091 31T003 100 2	44	C091 61N107 120 2	42	T 3261 004	12	T 3277 150	33
C091 11C107 000 2	45	C091 31D005 101 2	41	C091 31T004 100 2	44	C091 61N107 130 2	42	T 3261 005	13	T 3277 200	34
C091 11D003 000 2	41	C091 31D006 100 2	41	C091 31T005 100 2	44	FH 0300-091	47	T 3261 013	12	T 3277 500	33
C091 11D003 001 2	41	C091 31D006 101 2	41	C091 31T006 100 2	44	HN01 015 0005 (1)	46	T 3261 018	12	T 3277 518	33
C091 11D004 000 2	41	C091 31D007 100 2	41	C091 31T007 100 2	44	HN01 015 0005 (2)	46	T 3261 028	12	T 3277 550	33
C091 11D004 001 2	41	C091 31D007 101 2	41	C091 31T008 100 2	44	HN01 015 0039 (1)	46	T 3261 048	12	T 3277 600	34
C091 11D005 000 2	41	C091 31D008 100 2	41	C091 31T012 200 2	44	HN01 015 0039 (2)	46	T 3261 055	13	T 3277 900	34
C091 11D005 001 2	41	C091 31D008 101 2	41	C091 31T014 200 2	44	HN02 015 0005 (1)	46	T 3261 058	13	T 3278 501	30
C091 11D006 000 2	41	C091 31D012 100 2	41	C091 31T105 100 2	44	HN02 015 0005 (2)	46	T 3261 551	12	T 3278 502	30
C091 11D006 001 2	41	C091 31D012 200 2	41	C091 31T107 100 2	44	HN02 015 0039 (1)	46	T 3261 552	12	T 3278 504	30
C091 11D007 000 2	41	C091 31D012 201 2	41	C091 31W003 100 2	44	HN02 015 0039 (2)	46	T 3261 554	12	T 3278 518	30
C091 11D007 001 2	41	C091 31D014 100 2	41	C091 31W004 100 2	44	N 45 091-000 1	47	T 3262 000	18	T 3278 528	30
C091 11D008 000 2	41	C091 31D014 200 2	41	C091 31W005 100 2	44	T 2993 510 9C	47	T 3262 009	18	T 3278 548	30
C091 11D008 001 2	41	C091 31D014 201 2	41	C091 31W006 100 2	44	T 2993 510 9X	47	T 3262 018	18	T 3278 551	30
C091 11D105 000 2	41	C091 31D105 100 2	41	C091 31W007 100 2	44	T 2993 511 9C	47	T 3262 100	19	T 3278 552	30
C091 11D105 001 2	41	C091 31D105 101 2	41	C091 31W008 100 2	44	T 2993 511 9X	47	T 3262 150	19	T 3278 554	30
C091 11D107 000 2	41	C091 31D107 100 2	41	C091 31W012 200 2	44	T 2993 512 9C	47	T 3262 300	18	T 3278 951	32
C091 11D107 001 2	41	C091 31D107 101 2	41	C091 31W014 200 2	44	T 2993 512 9X	47	T 3262 400	19	T 3278 991	32
C091 11G003 000 2	43	C091 31G003 100 2	43	C091 31W105 100 2	44	T 2993 513 9C	47	T 3262 550	18	T 3279 501	26
C091 11G004 000 2	43	C091 31G004 100 2	43	C091 31W107 100 2	44	T 2993 513 9X	47	T 3263 000	14	T 3279 502	26
C091 11G005 000 2	43	C091 31G005 100 2	43	C091 61G003 110 2	43	T 3200 001	10	T 3263 009	14	T 3279 504	26
C091 11G006 000 2	43	C091 31G006 100 2	43	C091 61G003 120 2	43	T 3200 002	10	T 3263 018	14	T 3279 518	26
C091 11G007 000 2	43	C091 31G007 100 2	43	C091 61G003 130 2	43	T 3200 004	10	T 3263 100	15	T 3279 528	26
C091 11G008 000 2	43	C091 31G008 100 2	43	C091 61G004 110 2	43	T 3200 005	11	T 3263 109	15	T 3279 548	26
C091 11G105 000 2	43	C091 31G012 100 2	43	C091 61G004 120 2	43	T 3200 013	10	T 3263 118	15	T 3279 551	26
C091 11G107 000 2	43	C091 31G012 200 2	43	C091 61G004 130 2	43	T 3200 018	10	T 3263 150	15	T 3279 552	26
C091 11H003 000 2	40	C091 31G014 100 2	43	C091 61G005 110 2	43	T 3200 028	10	T 3263 300	14	T 3279 554	26
C091 11H003 001 2	40	C091 31G014 200 2	43	C091 61G005 120 2	43	T 3200 048	10	T 3263 320	14	T 3300 001	10
C091 11H004 000 2	40	C091 31G105 100 2	43	C091 61G005 130 2	43	T 3200 058	11	T 3263 330	14	T 3300 002	10
C091 11H004 001 2	40	C091 31G107 100 2	43	C091 61G006 110 2	43	T 3200 552	10	T 3263 400	15	T 3300 004	10
C091 11H005 000 2	40	C091 31H003 100 2	40	C091 61G006 120 2	43	T 3201 001	12	T 3263 420	15	T 3300 005	11
C091 11H005 001 2	40	C091 31H003 101 2	40	C091 61G006 130 2	43	T 3201 002	12	T 3263 430	15	T 3300 013	10
C091 11H006 000 2	40	C091 31H004 100 2	40	C091 61G007 110 2	43	T 3201 004	12	T 3263 550	17	T 3300 018	10
C091 11H006 001 2	40	C091 31H004 101 2	40	C091 61G007 120 2	43	T 3201 005	13	T 3263 900	14	T 3300 028	10
C091 11H007 000 2	40	C091 31H005 100 2	40	C091 61G007 130 2	43	T 3201 013	12	T 3271 500	33	T 3300 048	10
C091 11H007 001 2	40	C091 31H005 101 2	40	C091 61G008 110 2	43	T 3201 018	12	T 3271 518	33	T 3300 055	11
C091 11H008 000 2	40	C091 31H006 100 2	40	C091 61G008 120 2	43	T 3201 028	12	T 3271 550	33	T 3300 058	11
C091 11H008 001 2	40	C091 31H006 101 2	40	C091 61G008 130 2	43	T 3201 048	12	T 3274 005	24	T 3300 551	10
C091 11H105 000 2	40	C091 31H007 100 2	40	C091 61G012 110 2	43	T 3201 058	13	T 3274 055	24	T 3300 552	10
C091 11H105 001 2	40	C091 31H007 101 2	40	C091 61G012 210 2	43	T 3202 000	18	T 3274 058	24	T 3300 554	10
C091 11H107 000 2	40	C091 31H008 100 2	40	C091 61G014 110 2	43	T 3202 009	18	T 3274 501	24	T 3301 001	12
C091 11H107 001 2	40	C091 31H008 101 2	40	C091 61G014 210 2	43	T 3202 018	18	T 3274 502	24	T 3301 002	12
C091 11N003 000 2	42	C091 31H012 100 2	40	C091 61G105 110 2	43	T 3202 100	19	T 3274 504	24	T 3301 004	12
C091 11N004 000 2	42	C091 31H012 200 2	40	C091 61G105 120 2	43	T 3202 300	18	T 3274 518	24	T 3301 005	13
C091 11N005 000 2	42	C091 31H012 201 2	40	C091 61G105 130 2	43	T 3202 400	19	T 3274 528	24	T 3301 013	12
C091 11N006 000 2	42	C091 31H014 100 2	40	C091 61G107 110 2	43	T 3203 000	14	T 3274 548	24	T 3301 018	12
C091 11N007 000 2	42	C091 31H014 200 2	40	C091 61G107 120 2	43	T 3203 009	14	T 3274 551	24	T 3301 028	12
C091 11N008 000 2	42	C091 31H014 201 2	40	C091 61G107 130 2	43	T 3203 018	14	T 3274 552	24	T 3301 048	12
C091 11N105 000 2	42	C091 31H105 100 2	40	C091 61N003 110 2	42	T 3203 100	15	T 3274 554	24	T 3301 055	13
C091 11N107 000 2	42	C091 31H105 101 2	40	C091 61N003 120 2	42	T 3203 109	15	T 3274 951	32	T 3301 058	13
C091 11W003 000 2	44	C091 31H107 100 2	40	C091 61N003 130 2	42	T 3203 118	15	T 3274 991	32	T 3301 551	12
C091 11W004 000 2	44	C091 31H107 101 2	40	C091 61N004 110 2	42	T 3203 300	14	T 3275 005	28	T 3301 552	12
C091 11W005 000 2	44	C091 31N003 100 2	42	C091 61N004 120 2	42	T 3203 320	14	T 3275 055	28	T 3301 554	12
C091 11W006 000 2	44	C091 31N004 100 2	42	C091 61N004 130 2	42	T 3203 330	14	T 3275 058	28	T 3302 000	18
C091 11W007 000 2	44	C091 31N005 100 2	42	C091 61N005 110 2	42	T 3203 400	15	T 3275 501	28	T 3302 009	18
C091 11W008 000 2	44	C091 31N006 100 2	42	C091 61N005 120 2	42	T 3203 420	15	T 3275 502	28	T 3302 018	18
C091 11W105 000 2	44	C091 31N007 100 2	42	C091 61N005 130 2	42	T 3203 430	15	T 3275 504	28	T 3302 100	19
C091 11W107 000 2	44	C091 31N008 100 2	42	C091 61N006 110 2	42	T 3203 001	10	T 3275 518	28	T 3302 150	19
C091 31C003 100 2	45	C091 31N012 200 2	42	C091 61N006 120 2	42	T 3260 002	10	T 3275 528	28	T 3302 300	18
C091 31C004 100 2	45	C091 31N014 200 2	42	C091 61N006 130 2	42	T 3260 004	10	T 3275 548	28	T 3302 400	19
C091 31C005 100 2	45	C091 31N105 100 2	42	C091 61N007 110 2	42	T 3260 005	11	T 3275 551	28	T 3302 550	18
C091 31C006 100 2	45	C091 31N107 100 2	42	C091 61N007 120 2	42	T 3260 013	10	T 3275 552	28	T 3303 000	14

Summary of Part Numbers

Part Number	Page	Part Number	Page	Part Number	Page	Part Number	Page	Part Number	Page		
T 3303 009	14	T 3329 551	26	T 3361 130	12	T 3377 518	33	T 3399 504	26	T 3424 554	24
T 3303 018	14	T 3329 552	26	T 3361 551	12	T 3377 550	33	T 3399 518	26	T 3424 951	32
T 3303 100	15	T 3329 554	26	T 3361 552	12	T 3377 600	34	T 3399 528	26	T 3424 991	32
T 3303 109	15	T 3356 004	10	T 3361 554	12	T 3378 501	30	T 3399 548	26	T 3425 005	28
T 3303 118	15	T 3356 005	11	T 3362 000	18	T 3378 502	30	T 3399 551	26	T 3425 055	28
T 3303 150	15	T 3356 018	10	T 3362 009	18	T 3378 504	30	T 3399 552	26	T 3425 058	28
T 3303 300	14	T 3356 028	10	T 3362 010	18	T 3378 518	30	T 3399 554	26	T 3425 501	28
T 3303 320	14	T 3356 048	10	T 3362 018	18	T 3378 528	30	T 3400 001	10	T 3425 502	28
T 3303 330	14	T 3356 055	11	T 3362 100	19	T 3378 548	30	T 3400 002	10	T 3425 504	28
T 3303 400	15	T 3356 058	11	T 3362 150	19	T 3378 551	30	T 3400 004	10	T 3425 518	28
T 3303 420	15	T 3356 551	10	T 3362 300	18	T 3378 552	30	T 3400 005	11	T 3425 528	28
T 3303 430	15	T 3356 552	10	T 3362 400	19	T 3378 554	30	T 3400 013	10	T 3425 548	28
T 3303 550	14	T 3356 554	10	T 3362 550	18	T 3378 951	32	T 3400 018	10	T 3425 551	28
T 3321 500	33	T 3357 004	12	T 3363 218	16	T 3378 991	32	T 3400 028	10	T 3425 552	28
T 3321 518	33	T 3357 005	13	T 3363 228	16	T 3379 501	26	T 3400 048	10	T 3425 554	28
T 3321 550	33	T 3357 018	12	T 3363 000	14	T 3379 502	26	T 3400 055	11	T 3425 951	32
T 3324 005	24	T 3357 028	12	T 3363 009	14	T 3379 504	26	T 3400 058	11	T 3425 991	32
T 3324 055	24	T 3357 048	12	T 3363 010	14	T 3379 518	26	T 3400 551	10	T 3426 500	35
T 3324 058	24	T 3357 055	13	T 3363 018	14	T 3379 528	26	T 3400 552	10	T 3426 518	35
T 3324 501	24	T 3357 058	13	T 3363 100	15	T 3379 548	26	T 3400 554	10	T 3426 550	35
T 3324 502	24	T 3357 551	12	T 3363 109	15	T 3379 551	26	T 3401 001	12	T 3427 000	33
T 3324 504	24	T 3357 552	12	T 3363 118	15	T 3379 552	26	T 3401 002	12	T 3427 018	33
T 3324 518	24	T 3357 554	12	T 3363 150	15	T 3379 554	26	T 3401 004	12	T 3427 050	33
T 3324 528	24	T 3358 009	18	T 3363 300	14	T 3391 500	33	T 3401 005	13	T 3427 100	33
T 3324 548	24	T 3358 018	18	T 3363 320	14	T 3391 518	33	T 3401 013	12	T 3427 150	33
T 3324 551	24	T 3358 100	19	T 3363 330	14	T 3391 550	33	T 3401 018	12	T 3427 200	34
T 3324 552	24	T 3358 150	19	T 3363 400	15	T 3394 005	24	T 3401 028	12	T 3427 500	33
T 3324 554	24	T 3358 300	18	T 3363 420	15	T 3394 055	24	T 3401 048	12	T 3427 518	33
T 3324 951	32	T 3358 400	19	T 3363 430	15	T 3394 058	24	T 3401 055	13	T 3427 550	33
T 3324 991	32	T 3358 550	18	T 3363 550	14	T 3394 501	24	T 3401 058	13	T 3427 600	34
T 3325 005	28	T 3359 009	14	T 3363 902	16	T 3394 502	24	T 3401 551	12	T 3428 501	30
T 3325 055	28	T 3359 018	14	T 3371 500	33	T 3394 504	24	T 3401 552	12	T 3428 502	30
T 3325 058	28	T 3359 100	15	T 3371 518	33	T 3394 518	24	T 3401 554	12	T 3428 504	30
T 3325 501	28	T 3359 109	15	T 3371 550	33	T 3394 528	24	T 3402 000	18	T 3428 518	30
T 3325 502	28	T 3359 118	15	T 3374 005	24	T 3394 548	24	T 3402 009	18	T 3428 528	30
T 3325 504	28	T 3359 150	15	T 3374 055	24	T 3394 551	24	T 3402 018	18	T 3428 548	30
T 3325 518	28	T 3359 300	14	T 3374 058	24	T 3394 552	24	T 3402 100	19	T 3428 551	30
T 3325 528	28	T 3359 320	14	T 3374 501	24	T 3394 554	24	T 3402 150	19	T 3428 552	30
T 3325 548	28	T 3359 330	14	T 3374 502	24	T 3395 005	28	T 3402 300	18	T 3428 554	30
T 3325 551	28	T 3359 400	15	T 3374 504	24	T 3395 055	28	T 3402 400	19	T 3428 951	32
T 3325 552	28	T 3359 420	15	T 3374 518	24	T 3395 058	28	T 3402 550	18	T 3428 991	32
T 3325 554	28	T 3359 430	15	T 3374 528	24	T 3395 501	28	T 3403 218	16	T 3429 501	26
T 3325 951	32	T 3359 550	14	T 3374 548	24	T 3395 502	28	T 3403 228	16	T 3429 502	26
T 3325 991	32	T 3359 900	17	T 3374 551	24	T 3395 504	28	T 3403 000	14	T 3429 504	26
T 3326 500	35	T 3360 001	10	T 3374 552	24	T 3395 518	28	T 3403 009	14	T 3429 518	26
T 3326 518	35	T 3360 002	10	T 3374 554	24	T 3395 528	28	T 3403 018	14	T 3429 528	26
T 3326 550	35	T 3360 004	10	T 3374 951	32	T 3395 548	28	T 3403 100	15	T 3429 548	26
T 3327 000	33	T 3360 005	11	T 3374 991	32	T 3395 551	28	T 3403 109	15	T 3429 551	26
T 3327 018	33	T 3360 010	10	T 3375 005	28	T 3395 552	28	T 3403 118	15	T 3429 552	26
T 3327 050	33	T 3360 013	10	T 3375 055	28	T 3395 554	28	T 3403 150	15	T 3429 554	26
T 3327 100	33	T 3360 018	10	T 3375 058	28	T 3396 500	35	T 3403 300	14	T 3431 500	33
T 3327 150	33	T 3360 020	10	T 3375 501	28	T 3396 518	35	T 3403 320	14	T 3431 518	33
T 3327 500	33	T 3360 028	10	T 3375 502	28	T 3396 550	35	T 3403 330	14	T 3431 550	33
T 3327 518	33	T 3360 048	10	T 3375 504	28	T 3397 100	33	T 3403 400	15	T 3434 005	24
T 3327 550	33	T 3360 055	11	T 3375 518	28	T 3397 150	33	T 3403 420	15	T 3434 055	24
T 3328 501	30	T 3360 058	11	T 3375 528	28	T 3397 200	34	T 3403 430	15	T 3434 058	24
T 3328 502	30	T 3360 130	10	T 3375 548	28	T 3397 500	33	T 3403 550	14	T 3434 501	24
T 3328 504	30	T 3360 551	10	T 3375 551	28	T 3397 518	33	T 3403 902	16	T 3434 502	24
T 3328 518	30	T 3360 552	10	T 3375 552	28	T 3397 550	33	T 3421 500	33	T 3434 504	24
T 3328 528	30	T 3360 554	10	T 3375 554	28	T 3397 600	34	T 3421 518	33	T 3434 518	24
T 3328 548	30	T 3361 001	12	T 3375 951	32	T 3397 900	34	T 3421 550	33	T 3434 528	24
T 3328 551	30	T 3361 002	12	T 3375 991	32	T 3398 501	30	T 3424 005	24	T 3434 548	24
T 3328 552	30	T 3361 004	12	T 3376 500	35	T 3398 502	30	T 3424 055	24	T 3434 551	24
T 3328 554	30	T 3361 005	13	T 3376 518	35	T 3398 504	30	T 3424 058	24	T 3434 552	24
T 3328 951	32	T 3361 010	12	T 3376 550	35	T 3398 518	30	T 3424 501	24	T 3434 554	24
T 3328 991	32	T 3361 013	12	T 3377 000	33	T 3398 528	30	T 3424 502	24	T 3434 951	32
T 3329 501	26	T 3361 018	12	T 3377 018	33	T 3398 548	30	T 3424 504	24	T 3434 991	32
T 3329 502	26	T 3361 020	12	T 3377 050	33	T 3398 551	30	T 3424 518	24	T 3435 005	28
T 3329 504	26	T 3361 028	12	T 3377 100	33	T 3398 552	30	T 3424 528	24	T 3435 055	28
T 3329 518	26	T 3361 048	12	T 3377 150	33	T 3398 554	30	T 3424 548	24	T 3435 058	28
T 3329 528	26	T 3361 055	13	T 3377 200	34	T 3399 501	26	T 3424 551	24	T 3435 501	28
T 3329 548	26	T 3361 058	13	T 3377 500	33	T 3399 502	26	T 3424 552	24	T 3435 502	28

Summary of Part Numbers

Part Number	Page	Part Number	Page	Part Number	Page	Part Number	Page	Part Number	Page	Part Number	Page
T 3435 504	28	T 3447 500	33	T 3484 004	10	T 3505 554	12	T 3529 528	26	T 3644 504	24
T 3435 518	28	T 3447 518	33	T 3484 005	11	T 3506 000	18	T 3529 548	26	T 3644 518	24
T 3435 528	28	T 3447 550	33	T 3484 013	10	T 3506 009	18	T 3529 551	26	T 3644 528	24
T 3435 548	28	T 3447 900	34	T 3484 018	10	T 3506 018	18	T 3529 552	26	T 3644 548	24
T 3435 551	28	T 3448 501	30	T 3484 028	10	T 3506 100	19	T 3529 554	26	T 3645 005	28
T 3435 552	28	T 3448 502	30	T 3484 048	10	T 3506 150	19	T 3621 500	33	T 3645 058	28
T 3435 554	28	T 3448 504	30	T 3484 055	11	T 3506 300	18	T 3621 518	33	T 3645 501	28
T 3435 951	32	T 3448 518	30	T 3484 058	11	T 3506 400	19	T 3624 005	24	T 3645 502	28
T 3435 991	32	T 3448 528	30	T 3484 551	10	T 3506 550	18	T 3624 058	24	T 3645 504	28
T 3436 500	35	T 3448 548	30	T 3484 552	10	T 3507 000	14	T 3624 501	24	T 3645 518	28
T 3436 518	35	T 3448 551	30	T 3484 554	10	T 3507 009	14	T 3624 502	24	T 3645 528	28
T 3436 550	35	T 3448 552	30	T 3485 001	12	T 3507 018	14	T 3624 504	24	T 3645 548	28
T 3437 000	33	T 3448 554	30	T 3485 002	12	T 3507 100	15	T 3624 518	24	T 3646 500	35
T 3437 018	33	T 3449 501	26	T 3485 004	12	T 3507 109	15	T 3624 528	24	T 3646 518	35
T 3437 050	33	T 3449 502	26	T 3485 005	13	T 3507 118	15	T 3624 548	24	T 3647 100	33
T 3437 100	33	T 3449 504	26	T 3485 013	12	T 3507 150	15	T 3625 005	28	T 3647 500	33
T 3437 150	33	T 3449 518	26	T 3485 018	12	T 3507 300	14	T 3625 058	28	T 3647 518	33
T 3437 500	33	T 3449 528	26	T 3485 028	12	T 3507 320	14	T 3625 501	28	T 3648 501	30
T 3437 518	33	T 3449 548	26	T 3485 048	12	T 3507 330	14	T 3625 502	28	T 3648 502	30
T 3437 550	33	T 3449 551	26	T 3485 055	13	T 3507 400	15	T 3625 504	28	T 3648 504	30
T 3438 501	30	T 3449 552	26	T 3485 058	13	T 3507 420	15	T 3625 518	28	T 3648 518	30
T 3438 502	30	T 3449 554	26	T 3485 551	12	T 3507 430	15	T 3625 528	28	T 3648 528	30
T 3438 504	30	T 3475 001	10	T 3485 552	12	T 3507 550	14	T 3625 548	28	T 3648 548	30
T 3438 518	30	T 3475 002	10	T 3485 554	12	T 3507 900	17	T 3626 500	35	T 3649 501	26
T 3438 528	30	T 3475 004	10	T 3486 000	18	T 3521 500	33	T 3626 518	35	T 3649 502	26
T 3438 548	30	T 3475 005	11	T 3486 009	18	T 3521 518	33	T 3627 100	33	T 3649 504	26
T 3438 551	30	T 3475 013	10	T 3486 018	18	T 3521 550	33	T 3627 500	33	T 3649 518	26
T 3438 552	30	T 3475 018	10	T 3486 100	19	T 3524 005	24	T 3627 518	33	T 3649 528	26
T 3438 554	30	T 3475 028	10	T 3486 150	19	T 3524 055	24	T 3628 501	30	T 3649 548	26
T 3438 951	32	T 3475 048	10	T 3486 300	18	T 3524 058	24	T 3628 502	30	T 3650 000	10
T 3438 991	32	T 3475 055	11	T 3486 400	19	T 3524 501	24	T 3628 504	30	T 3650 001	10
T 3439 501	26	T 3475 058	11	T 3486 550	18	T 3524 502	24	T 3628 518	30	T 3650 002	10
T 3439 502	26	T 3475 551	10	T 3487 000	14	T 3524 504	24	T 3628 528	30	T 3650 004	10
T 3439 504	26	T 3475 552	10	T 3487 009	14	T 3524 518	24	T 3628 548	30	T 3650 005	11
T 3439 518	26	T 3475 554	10	T 3487 018	14	T 3524 528	24	T 3629 501	26	T 3650 058	11
T 3439 528	26	T 3476 001	12	T 3487 100	15	T 3524 548	24	T 3629 502	26	T 3651 000	12
T 3439 548	26	T 3476 002	12	T 3487 109	15	T 3524 551	24	T 3629 504	26	T 3651 001	12
T 3439 551	26	T 3476 004	12	T 3487 118	15	T 3524 552	24	T 3629 518	26	T 3651 002	12
T 3439 552	26	T 3476 005	13	T 3487 150	15	T 3524 554	24	T 3629 528	26	T 3651 004	12
T 3439 554	26	T 3476 013	12	T 3487 300	14	T 3525 005	28	T 3629 548	26	T 3651 005	13
T 3441 500	33	T 3476 018	12	T 3487 320	14	T 3525 055	28	T 3635 000	10	T 3651 058	13
T 3441 518	33	T 3476 028	12	T 3487 330	14	T 3525 058	28	T 3635 001	10	T 3652 000	18
T 3441 550	33	T 3476 048	12	T 3487 400	15	T 3525 501	28	T 3635 002	10	T 3652 001	18
T 3444 005	24	T 3476 055	13	T 3487 420	15	T 3525 502	28	T 3635 004	10	T 3652 009	18
T 3444 055	24	T 3476 058	13	T 3487 430	15	T 3525 504	28	T 3635 005	11	T 3652 100	19
T 3444 058	24	T 3476 551	12	T 3487 550	14	T 3525 518	28	T 3635 058	11	T 3652 304	18
T 3444 501	24	T 3476 552	12	T 3487 900	17	T 3525 528	28	T 3636 000	12	T 3652 404	19
T 3444 502	24	T 3476 554	12	T 3504 001	10	T 3525 548	28	T 3636 001	12	T 3653 000	14
T 3444 504	24	T 3477 000	18	T 3504 002	10	T 3525 551	28	T 3636 002	12	T 3653 004	14
T 3444 518	24	T 3477 009	18	T 3504 004	10	T 3525 552	28	T 3636 004	12	T 3653 009	14
T 3444 528	24	T 3477 018	18	T 3504 005	11	T 3525 554	28	T 3636 005	13	T 3653 100	15
T 3444 548	24	T 3477 100	19	T 3504 013	10	T 3526 500	35	T 3636 058	13	T 3653 109	15
T 3444 551	24	T 3477 150	19	T 3504 018	10	T 3526 518	35	T 3637 000	18	T 3653 118	15
T 3444 552	24	T 3477 300	18	T 3504 028	10	T 3526 550	35	T 3637 001	18	T 3653 304	14
T 3444 554	24	T 3477 400	19	T 3504 048	10	T 3527 100	33	T 3637 009	18	T 3653 404	15
T 3445 005	28	T 3477 550	18	T 3504 055	11	T 3527 150	33	T 3637 100	19	VN 05 180 000 1 (1)	47
T 3445 055	28	T 3478 000	14	T 3504 058	11	T 3527 500	33	T 3637 304	18	VN01 015 0005 (1)	46
T 3445 058	28	T 3478 009	14	T 3504 551	10	T 3527 518	33	T 3637 404	19	VN01 015 0005 (2)	46
T 3445 501	28	T 3478 018	14	T 3504 552	10	T 3527 900	34	T 3638 000	14	VN01 015 0039 (1)	46
T 3445 502	28	T 3478 100	15	T 3504 554	10	T 3528 501	30	T 3638 004	14	VN01 015 0039 (2)	46
T 3445 504	28	T 3478 109	15	T 3505 001	12	T 3528 502	30	T 3638 009	14	VN02 015 0005 (1)	46
T 3445 518	28	T 3478 118	15	T 3505 002	12	T 3528 504	30	T 3638 100	15	VN02 015 0005 (2)	46
T 3445 528	28	T 3478 150	15	T 3505 004	12	T 3528 518	30	T 3638 109	15	VN02 015 0039 (1)	46
T 3445 548	28	T 3478 300	14	T 3505 005	13	T 3528 528	30	T 3638 118	15	VN02 015 0039 (2)	46
T 3445 551	28	T 3478 320	14	T 3505 013	12	T 3528 548	30	T 3638 304	14	ZN01 015 0005 (1)	46
T 3445 552	28	T 3478 330	14	T 3505 018	12	T 3528 551	30	T 3638 404	15	ZN01 015 0005 (2)	46
T 3445 554	28	T 3478 400	15	T 3505 028	12	T 3528 552	30	T 3641 500	33	ZN01 015 0039 (1)	46
T 3446 500	35	T 3478 420	15	T 3505 048	12	T 3528 554	30	T 3641 518	33	ZN01 015 0039 (2)	46
T 3446 518	35	T 3478 430	15	T 3505 055	13	T 3529 501	26	T 3644 005	24	ZN02 015 0005 (1)	46
T 3446 550	35	T 3478 550	14	T 3505 058	13	T 3529 502	26	T 3644 058	24	ZN02 015 0005 (2)	46
T 3447 100	33	T 3484 001	10	T 3505 551	12	T 3529 504	26	T 3644 501	24	ZN02 015 0039 (1)	46
T 3447 150	33	T 3484 002	10	T 3505 552	12	T 3529 518	26	T 3644 502	24	ZN02 015 0039 (2)	46

Representatives: Europe

Amphenol Benelux BV
Peppelkade 2 a
NL-3992 AK Houten
Phone +31 / 30 / 635 8000
Fax +31 / 30 / 637 7034
E-mail: info@amphenol-nl.com

Amphenol Ges. m. b. H.
Johnstraße 42, Top 3A
A-1150 Wien
Phone +43 / 1 / 985 15 11
Fax +43 / 1 / 982 61 01
Telex 132 661 amphw a
E-mail: info@amphenol-at.com

Amphenol Ibérica
Calle Cuba No. 6, 2-5
E-28820 Coslada
Madrid, Spain
Phone +34 / 91 / 673 / 22 35
Fax +34 / 91 / 674 / 08 93
E-mail: info@amphenol-nl.com

Amphenol Italia S.p.A.
Galleria Gandhi, 2/27
I-20017 Mazzo di Rho
(Milano)
Phone +39 / 2 / 93 90 41 92
Fax +39 / 2 / 93 90 10 30
E-mail: info@amphenol-it.com

Amphenol Limited
Thanet Way, Whitstable
GB-Kent CT5 3JF
Phone +44 / 1227 / 773200
Fax +44 / 1227 / 771773
Telex 851966507

Amphenol Poland
18 Niedurnego St.
41-600 Swietochlowice
(Katowice), Poland.
Phone +48 / 32 / 45 36 34
Fax +48 / 32 / 45 36 34
Mobile +48 / 601 / 42 13 64
E-mail: info@amphenol-at.com

Amphenol Scandinavia
Johanneslundsvägen 2
S-194 61 Upplands Väsby
Phone +46 / 8 / 59 41 04 40
Fax +46 / 8 / 59 03 38 00
E-mail: info@amphenol-se.com

Amphenol Socapex France
11 Avenue Durbonnet
BP 5
F-92407 Courbevoie Cedex
Phone +33 / 1 / 49 05 30 00
Fax +33 / 1 / 49 05 30 43
Telex MSTH 215 709 F

Amphenol Switzerland
Route du Roule 41
CH-1723 Marly
Phone +41 / 26 / 4 36 38 18
Fax +41 / 26 / 4 30 01 77
E-mail: info@amphenol-nl.com

Representatives: North America

Amphenol Corporation
Corporate Headquarters
358 Hall Avenue
Wallingford, CT 06492
Phone +1 / 203 / 265 / 8900
Fax +1 / 203 / 265 / 8628

Amphenol-Tuchel Electronics
Representative Office
6900 Haggerty Road
Suite 200
Canton, Michigan 48187
Phone +1 / 734 / 451 6400
Fax +1 / 734 / 451 7197

Representatives: Asia

Amphenol East Asia Limited
Units 3-19, 10/F & 11/F
Wah Luen Industrial Centre
15-21 Wong Chuk Yeung Street
Fotan, Shatin, N T, Hong Kong
Phone +852 / 26 99 / 26 63
Fax +852 / 26 88 / 09 74
Telex 36502 AMPEA HX

Amphetrnix Limited
Plot No. 105 Bhosari
Industrial Area
Pune - 411 026
India
Phone +91 / 2 12 / 79 03 63
Fax +91 / 2 12 / 79 05 81
Telex 953 146237

Amphenol Japan, K.K.
2-3-27, Kudan Minami
Chiyoda-Ku
Tokyo 102
Japan
Phone +81 / 3 / 32 63 / 56 11
Fax +81 / 3 / 52 76 / 70 59

Amphenol Kai Jack
No. 110, Sec 1
Bao-An Road
Ren-Der Shiang
Tainan, Taiwan
Phone +886 / 6 / 266 / 1011
Fax +886 / 6 / 266 / 4633

Representatives: Australia & New Zealand

Amphenol Australia Ltd.
248 Wickham Road,
Moorabbin
Victoria 3189, Melbourne
Australia
Phone +61 / 3 / 9555 / 1566
Fax +61 / 3 / 9553 / 3801

Your engineering sales representative:

Amphenol-Tuchel Electronics GmbH

August-Haeusser- Str. 10 · D-74080 Heilbronn · Phone +49/(0)71 31/9 29-0 · Telefax +49/(0)71 31/9 29-486

Printed on chlorine-free bleached paper. Specifications may be changed without notice. Copyright 02/00 by Amphenol-Tuchel Electronics GmbH, Germany